

# nano

## Technical Manual



# *Nano* Mini-Exhibition

## Technical Manual

This manual is divided into three sections: **Installation, Maintenance, Reference**.

The first section, **Installation**, contains detailed instructions to assemble and prepare your exhibition for visitor use. It is also referred to extensively in the troubleshooting portion of this manual.

Read through the second section, **Maintenance**, to familiarize yourself with the routine upkeep needed to keep your exhibition functioning at its best. This section also contains instructions for troubleshooting of the exhibition components, should this be necessary.

The third section, **Reference**, contains layout suggestions, component dimensions, off-the-shelf replacement part numbers, wiring diagrams, and MSDS information.

# TABLE OF CONTENTS

<b>INSTALLATION</b>	<b>4</b>
• Small, Smaller, Nano	5
• Static vs. Gravity	14
• Build a Giant Carbon Nanotube	16
• I Spy Nano	17
• Balance Our Nano Future	21
• Vertical Panels and Attached Tables	23
• Seating and Reading Area	6
○ Reading Table	24
○ Sofa and Armchair	25
<b>MAINTENANCE</b>	<b>26</b>
• Routine Upkeep	27
• Troubleshooting	29
<b>REFERENCE</b>	<b>35</b>
• Suggested Layouts	35
• Component Dimensions	37
• Replacement Parts	38
• Wiring Diagrams	42
• MSDS Information	43
<b>SHIPPING</b>	<b>52</b>
• Shipping Materials	52
• Shipping Manifest	53
• Pallet Contents and Illustrations	54
<b>EXHIBITION COMMITMENTS</b>	<b>62</b>
• Ownership Agreement	62
• Exhibition Disposal	65

# INSTALLATION

This section contains instructions to prepare your exhibition for visitor use. In order to keep shipping costs down several components have been shipped disassembled. All of the necessary hardware has been included and can be found in the small box labeled **MANUALS**.

## You will need to supply the following tools and materials:

- #2 Phillips screwdriver or a drill with a Phillips bit
- 7/16" wrench
- 7/16" socket
- 3/32" Allen wrench
- 5/32" Allen wrench
- Tape measure
- Small mallet
- Tap water
- Extension cord

When unpacking and assembling your copy of the *Nano* exhibition, please note that very few of the shipping materials need to end up in a landfill. The boxes and nearly all of the packing material can be recycled, and if your institution doesn't have a need for the pallets a short search on the Internet is all it takes to find somebody near you that does. There is an entire industry devoted to the reuse and recycling of pallets. With so many copies of this exhibition being transported such large distances, we do appreciate your help in minimizing its environmental impact.

## SMALL, SMALLER, NANO

### EXHIBIT PARTS/HARDWARE

- SMALL, SMALLER, and NANO tabletop sections (3)
- 3x 30½" table legs (one with small flange on side)
- 4x 29" table legs
- 3x 27½" table legs
- 39x 1" #10 panhead screws
- 39x #10 washers
- 5x 2½" hex head lag bolts
- 1x 1" hex head lag bolt
- 6x ¼" washers
- 3x Stools

### TOOLS/MATERIALS

- #2 Phillips screwdriver or drill with Phillips bit
- 7/16" socket
- Tape measure

NOTE: When fully assembled, the SMALL, SMALLER, NANO table is large and awkward to move. Assemble it as near to its final location as possible.

### SMALL, SMALLER, NANO TABLE ASSEMBLY

Locate the SMALLER tabletop and the four 29" table legs.

With the tabletop facedown, align the holes on the table legs with the holes at the corners of the tabletop.

Slide a #10 washer onto each 1" #10 panhead screw, and drive the screws into the holes using a Phillips screwdriver or a drill (note that one of the predrilled holes is larger than the others and is drilled all the way through the tabletop. Leave this hole empty for now: it will be used later to attach the tabletops together).

Turn the table upright.



Locate the SMALL tabletop and the three 30½” table legs.

One end of this tabletop will only have holes for one table leg: this is where the table leg with the small flange will be attached. Align the holes of this leg so that the flange faces out toward the short side of the table. Attach this leg, then the remaining two, as you have on the other tables.



Turn the table upright.

On the SMALLER table, locate the hole 8” from the right and 2” from the back of the tabletop.



On underside of the SMALL table, locate the hole nearest to “legless” corner.



Move the tables so the two holes you have just located line up with each other (the tables should look like the photo at right).



Slide a ¼" washer onto a 2½" hex head lag bolt, and insert the lag bolt upwards through the hole in the SMALLER table and into the hole in the SMALL table.

Adjust the tables until the empty hole in the SMALLER table's leg lines up with the hole on the underside of the SMALL table.



Slide a ¼" washer onto the 2½" hex head lag bolt, and insert the lag bolt upwards through the empty hole of the SMALLER table's legs, and into the corresponding hole on the underside of the SMALL table.

Tighten the lag bolts lightly with a 7/16" socket.

Locate the NANO tabletop. With the tabletop face down, attach the three 27½" legs in the same manner as the others.

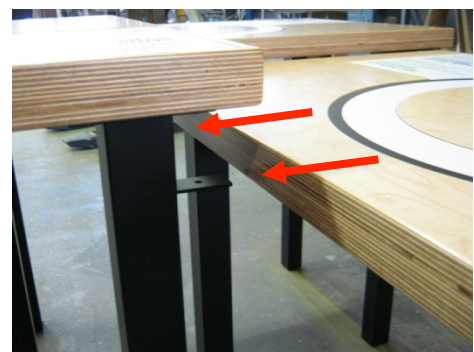

Turn the table upright, and slide the back of the NANO table onto the small flange of the SMALL table's leg.

Slide the NANO table to the right until the hole in the flange lines up with the hole in the underside of the NANO tabletop (the SMALLER tabletop will overlap the NANO table by a couple of inches when properly aligned).



Slide a  $\frac{1}{4}$ " washer onto the  $\frac{3}{4}$ " hex head lag bolt, and insert the lag bolt through the small flange and into hole in the NANO tabletop.

Tighten the lag bolt lightly with a  $\frac{7}{16}$ " socket.



Place a stool at the front side of each table.

Locate the three holes underneath the right side of the NANO table. Adjust the tables until these holes line up with corresponding holes on the underside of the SMALLER tabletop.

Slide  $\frac{1}{4}$ " washers onto three 2" lag bolts, and insert the lag bolts into each of these holes.

Tighten all six of the lag bolts with a  $\frac{7}{16}$ " socket.





## SMALL, SMALLER, NANO INTERACTIVE ASSEMBLY

### EXHIBIT PARTS/HARDWARE

- 3x 13" round plywood bases
- 3x triangular plywood caps
- 3x 12" acrylic cylinders
- 9x 12¾" stainless steel tubes
- 9x 15¼" stainless steel threaded rod/locknut assemblies
- 18x ¼" washers
- 9x ¼" lock washers
- 9x ¼" hex nuts
- 6x black magnetic wands
- 1x 32oz premixed ferrofluid bottle
- 2x empty 32oz glass bottles
- Coarse magnetite sand
- Fine magnetite powder
- Bleach

### TOOLS/MATERIALS

- 7/16" socket
- 7/16" wrench
- Small mallet (optional)
- Tap water

NOTE: The three glass bottles fit snugly inside the acrylic tubes, but should not need to be forced in. Because of slight irregularities in the two products, it may be necessary to try each bottle in each tube to ensure the easiest assembly and best fit.

### NANO Tabletop Interactive

Place one of the 13" round plywood bases onto the NANO tabletop. Align the three holes in the base with the holes in the tabletop.

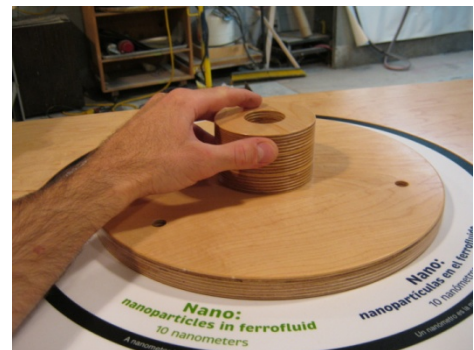

Locate the stainless steel rod/tube assemblies.

Remove the nut, lockwasher, and washer from the ends of three of the threaded rods. Slide the tubes off of the threaded rods, and set the threaded rods and hardware aside.

Press the three of the 12 $\frac{3}{4}$ " stainless steel tubes into the holes in the base (the fit will be tight, and a few light taps from a mallet may be necessary).

Slide the two black magnetic wands onto the front two stainless steel tubes.

Slide one of the 12" acrylic tubes over the raised "puck" at the center of the base.

Shake the premixed ferrofluid bottle vigorously for 10-15 seconds. This helps break up a slight "skin" that can sometimes form on the ferrofluid during shipping.

When finished, slide the bottle into the acrylic tube

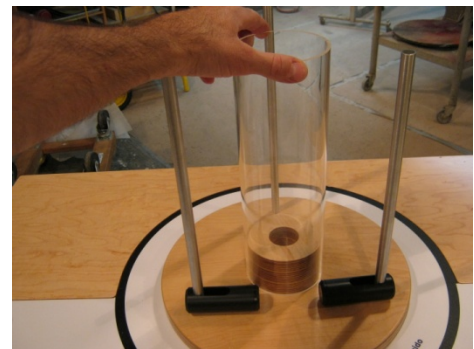
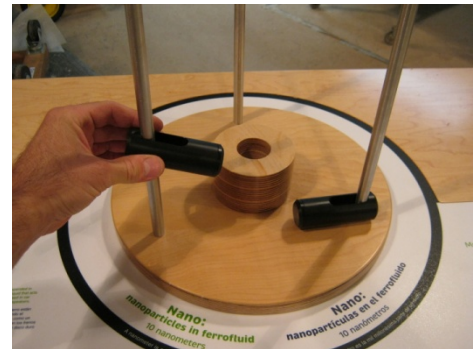
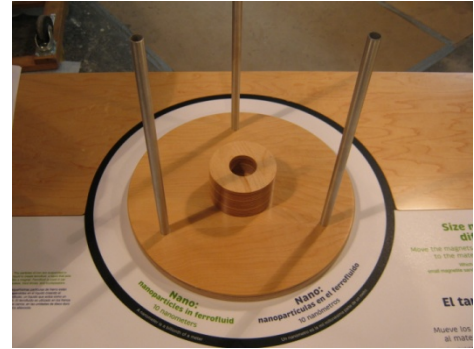

Lower the triangular plywood cap onto the whole assembly.

Align the holes in the plywood cap with the three stainless steel tubes, and press the tubes into the holes (again, a few light taps from a mallet will help if the fit is tight).

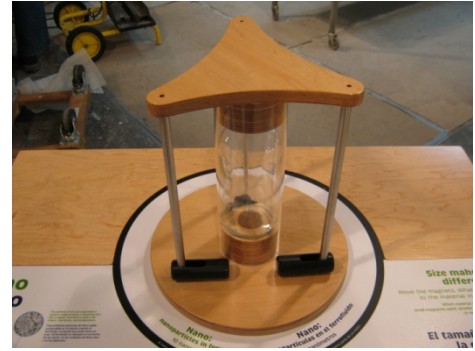

Insert the three threaded rods into the holes in plywood cap. Slide the rods down through the assembled cap, tube, base, and tabletop.

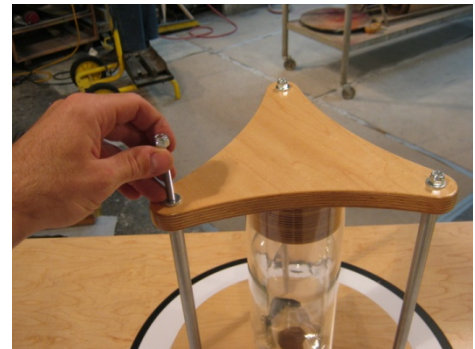

Underneath the tabletop, thread the 1/4" washers, lock washers, and nuts onto the bottom of each threaded rod.

Tighten the nuts on the three rods using a 7/16" wrench and socket.



### SMALL Tabletop Interactive

Add a few teaspoons of the coarse magnetite sand to an empty 32oz glass bottle.



Fill the bottle with tap water. The coarse magnetite sand is harvested directly from nature and will be dirty, necessitating filling the bottle with water, shaking it, and dumping the dirty water (but not the magnetite) out several times.



When the water remains clean enough to satisfy you, add a few drops of bleach to the mixture and cap tightly. This will help inhibit the possibility of algae growth within the bottle.



Tilt the bottle so that the magnetite sand falls to one side. This will be the “front,” and should be the side that you place towards the magnetic wands on the tabletop.

Follow the NANO Tabletop Interactive instructions for remainder of assembly.



### SMALLER Tabletop Interactive

Add a few teaspoons of the fine magnetite powder to an empty 32oz glass bottle.



Fill the bottle with tap water, add a few drops of bleach, and cap tightly. The powder is very fine and will take several minutes to settle to the bottom of the bottle. The magnetic wands can be used to speed this process up if necessary.



Use one of the magnetic wands to pull the magnetite powder to one side of the bottle. This will be the "front," and should be the side that you place towards the magnetic wands on the tabletop.

Follow the NANO Tabletop Interactive instructions for remainder of assembly.



## STATIC VS. GRAVITY

### EXHIBIT PARTS/HARDWARE

- STATIC VS. GRAVITY tabletop
- 4x 22½" table legs
- 2x spinning disk stands
- 2x spinning disks
- 4x ¼" bearings
- 2x ¼" shaft collars
- 24x 1" #10 panhead screws
- 24x #10 washers

### TOOLS/MATERIALS

- #2 Phillips screwdriver or drill with Phillips bit
- 3/32" Allen wrench
- Tape measure

Locate the STATIC VS. GRAVITY tabletop and the four 22½" table legs.

With the tabletop facedown, align the holes on the table legs with the holes at the corners of the tabletop.

Slide a #10 washer onto each 1" #10 panhead screw, and drive the screws into the holes using a Phillips screwdriver or a drill.

Turn the table upright, and align the spinning disk stands with the holes on the tabletop. The stands should lean away from the graphic.

Screw the stands to the tabletop in the same manner as the legs.



Place a ¼" bearing into the front and rear of the hole found at the top of each stand.



Slide the shaft of the spinning disks through the bearings (the disk with the small beads goes on the left).



Slide a ¼" shaft collar onto the shaft at the back of each stand.



Hold the spinning disk and shaft collar tight against the bearings and tighten the shaft collar using a 3/32" Allen wrench.



## BUILD A GIANT CARBON NANOTUBE

### EXHIBIT PARTS/HARDWARE

- BUILD A GIANT CARBON NANOTUBE base
- Set of black “Carbon Atom” pucks and gray connecting pieces

No assembly is needed for the BUILD A GIANT CARBON NANOTUBE component; simply move it to its final location. It has been shipped with a full set of building pieces already in the trough.

A spare set of building pieces has been included and should be stored in a secure location. See the **Reference** section for more information.





## I SPY NANO INTERACTIVES

### EXHIBIT PARTS/HARDWARE

- I SPY NANO INTERACTIVE
- 4x  $\frac{3}{8}$ "-16 levelers

### TOOLS/MATERIALS

- Flathead screwdriver
- #2 Phillips screwdriver
- Extension cord
- Drill with Phillips bit (optional)

Carefully lay the I SPY NANO vertical panel on its back, so the attached table is facing upwards. (Note: the graphic header for I Spy Nano asks, "Where can you find nano?")



Thread the  $\frac{3}{8}$ "-16 levelers all the way into the nuts located on the bottom of the exhibit.

Stand the exhibit back up and slide it into its final location.



Adjust the levelers so that the exhibit is level and stable. A flathead screwdriver can be used to adjust the levelers at the rear of exhibit, while those in front will have to be carefully adjusted by hand.



Locate “Smell Bottle” interactive at the left side of the attached table.

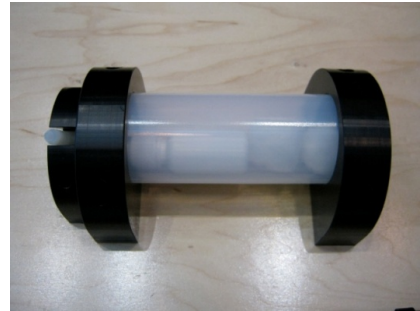

Using a #2 Phillips screwdriver, remove the screws in the mounting block at the right side of the bottle.

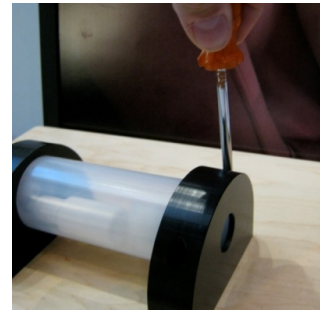

Remove the bottle and the mounting block by lifting up on the right side of the bottle and pulling it free from the mounting blocks at the left.



Open the squeeze bottle and remove the orange extract and cotton balls. Soak one of the cotton balls with orange extract, place it inside the squeeze bottle and close the bottle tightly.



Re-insert the bottle back into the mounting blocks at the left. You will need to start with the bottle tilted up from the attached table.



Align the holes of the mounting block at the right with those in the attached table, and reattach the block using the #2 Phillips screwdriver.

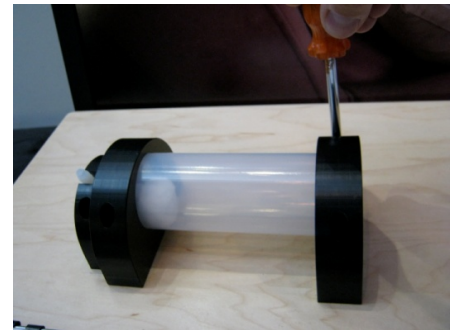

Using an extension cord, plug the exhibit in (the outlet on the exhibit is located underneath the attached table).



Test the volume of the speaker by pressing the button to the right of the computer chip graphic.

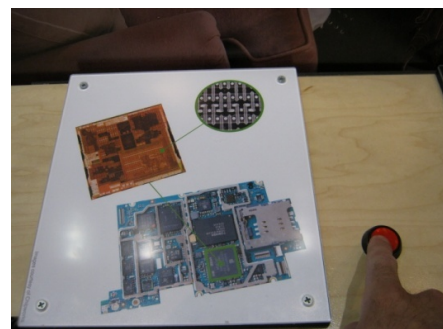

If necessary, adjust the volume by removing the panel on the underside of the attached table with a #2 Phillips screwdriver or drill.

Turn the small red knob on the MP3 player until you are satisfied with the volume, and replace the panel.

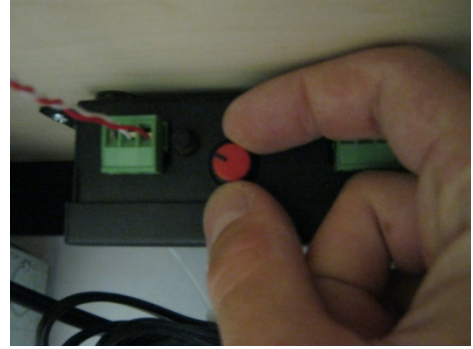

Test the lighting in the Blue Morpho butterfly case by pressing the button to the right of the butterfly. The wing on the right side should be backlit when the button is pressed.



## BALANCE OUR NANO FUTURE

### EXHIBIT PARTS/HARDWARE

- BALANCE OUR NANO FUTURE table
- 2x 16mm shaft collars
- Steel counterweight
- Set of blocks, cars, trees
- Up to 4x stools

### TOOLS/MATERIALS

- 5/32" Allen wrench

Locate the table.



Underneath the carpeted panels, slide a 16mm shaft collar, the steel counterweight, and another 16mm shaft collar (in that order) about a third of the way onto the shaft.



Tighten the bottom shaft collar using a 5/32" Allen wrench.



Add a full set of blocks, cars, and trees to the carpeted panels, and test the “tippyness” of the table by balancing them on the tippy platform. Adjust the height of the counterweight accordingly, and when you are satisfied tighten both shaft collars.

Up to four stools should accompany this exhibit.

A spare set of blocks has been included and should be stored in a secure location. See the **Reference** section for more information.



## VERTICAL PANELS AND ATTACHED TABLES

### EXHIBIT PARTS/HARDWARE

- 3x Vertical Panels and Attached Tables
- 12x  $\frac{3}{8}$ "-16 levelers

### TOOLS/MATERIALS

- Flathead screwdriver

Carefully lay each vertical panel on its back, so that the attached table is facing upwards.



Thread the  $\frac{3}{8}$ "-16 levelers all the way into the nuts located on the bottom of the exhibits.

Stand the exhibits back up and slide them into their final location.



Adjust the levelers so that the exhibits are level and stable. A flathead screwdriver can be used to adjust the levelers at the rear of each exhibit, while those in front will have to be carefully adjusted by hand.



## READING TABLE

### EXHIBIT PARTS/HARDWARE

- READING TABLE tabletop
- 4x 16½" table legs
- canvas book pocket
- reading cards/books
- 16x 1" #10 panhead screws
- 16x #10 washers

### TOOLS/MATERIALS

- #2 Phillips screwdriver or drill with Phillips bit
- Tape measure

Locate the READING TABLE tabletop and the four 16½" table legs.

With the tabletop facedown, align the holes on the table legs with the holes at the corners of the tabletop.

Slide a #10 washer onto each 1" #10 panhead screw, and drive the screws into the holes using a Phillips screwdriver or a drill.

Turn the table upright, and fill the pockets with the reading cards and books.





## SOFA AND ARMCHAIR

### EXHIBIT PARTS/HARDWARE

- 5x IKEA boxes

Locate the five IKEA boxes. Inside you should find all the necessary instructions, parts, and hardware to assemble the sofa and armchair. Instructions are also available online at [www.ikea.com](http://www.ikea.com). If anything is missing, please contact or visit an IKEA store for the appropriate replacements. Ordering information can be found in the **Reference** section.

When finished, add the plush gecko and blue morpho butterfly to the sofa or armchair.



# MAINTENANCE

Every effort has been made to minimize the routine upkeep and potential maintenance of the exhibition. As with any public interactive exhibit, however, there is a small amount of housekeeping that will need to be done and, on rare occasions, some troubleshooting or repairs may be necessary.

Familiarize yourself with the following pages on **Routine Upkeep**, and refer to the pages on **Troubleshooting** if a problem with one of the components arises.

## ROUTINE UPKEEP

The best way to avoid the **Troubleshooting** section is to check up on the exhibition: make a point to walk through and use each of the components several times a week. Repairs can often be avoided by simply noticing when components need to be cleaned or adjusted.

## SMALL, SMALLER, NANO

Occasionally a portion of the magnetite sand or powder will end up at the backside of the bottles. Though most of this material can usually be pulled back to the front using the magnetic wands, it is often quicker and easier to use a magnet not attached to the exhibit to move the material back to the front of the bottle.

## STATIC VS. GRAVITY

This component shouldn't need any routine upkeep other than cleaning. However, the cleaning procedure for this particular component requires one item of note: DO NOT USE A RAG THAT HAS BEEN DAMPENED, especially with acrylic or glass cleanser. Any moisture that seeps into the disks will diminish the static charge, but acrylic and glass cleansers are specifically designed to dissipate static electricity and can cause the exhibit to stop functioning altogether. Use only a clean, dry cloth when cleaning the spinning disks of this component.

## BUILD A GIANT CARBON NANOTUBE

Keep tabs on the Carbon Atom and Molecular Bond pieces: a full set of replacements has been included with your exhibition, but keep in mind that this is a custom product and may be prohibitively expensive to have additional single sets made. Contact information for the manufacturer can be found in the **Reference** section.

## I SPY NANO INTERACTIVES

Every month or two the orange smell will fade from the “Smell Nano” interactive and the old cotton ball will need to be replaced with a fresh one. To do this, remove the mounting block at the right side of the squeeze bottle with a #2 Phillips screwdriver. Lift the bottle free from the mounting blocks at the left, open the bottle, and replace the old cotton ball with one that has been newly saturated with orange extract. Close the bottle tightly and reassemble the component. The alcohol smell will dissipate within the first few days, leaving behind only the orange scent. If the alcohol smell is a problem, soak the cotton ball in the extract several days before you plan on installing it in the interactive and add it to the exhibit once the alcohol scent is gone. A small amount of orange extract has been included with your exhibition; additional extract is available at grocery stores.

Depending on use, the touchable “fur” in the “Benny the Bear” interactive will occasionally need replacing. To do this, remove the four screws at the corners of the graphic using a #2 Phillips screwdriver. Peel the fur off of the mounting block. Spray the back of the new fur with a craft adhesive, stick it to the block, and trim the fur to size. Reassemble the graphic. A small amount of replacement fur has been included with your exhibition, additional material is inexpensive and readily available at fabric stores.

## BALANCE OUR NANO FUTURE

The blocks, trees, and cars will eventually show signs of wear and tear or (like any loose pieces on a museum floor) get lost. Replacements have been included with your exhibition. The trees are manufactured by Haba and additional replacements can be ordered directly from them or through any number of toy stores. The cars are available from Maple Landmark Woodcraft, as are the custom blocks. Contact information for both of these companies can be found in the **Reference** section.

## TROUBLESHOOTING

The procedures on the following pages should occur infrequently enough that they don't qualify as routine upkeep. How often you need to refer to this section depends entirely on how heavily your copy of the exhibition is used. A small amount of spare materials have been included with the exhibition and, whenever possible, off-the-shelf items have been used in the fabrication and can be easily ordered to replace worn or broken parts. A complete list of those items is found in the **Reference** section.

### SMALL, SMALLER, NANO

To replace any the SMALL or SMALLER bottles, reverse the instructions found in the **Installation** section to remove the bottle. Dump the contents of the bottle out, thoroughly wash the bottle, and follow the **Installation** instructions to replace the contents and reinstall the bottle. A small amount of extra magnetite powder and sand has been included with your exhibition. See the **Reference** section for ordering information if additional quantities are needed.

Should your ferrofluid bottle break or leak, don't worry: ferrofluid is relatively harmless, though it will stain nearly anything it touches. (See the MSDS in the **Reference** section.) Lacquer thinner does the best job of removing the stains, but it should not be used on the wooden tabletop as it will damage the finish. Dish detergent or a degreaser such as Simple Green can be used to wipe the tabletop clean. Follow the recommended safety precautions for whatever cleaning product or solvent that you use. To replace the ferrofluid bottle, reverse the instructions found in the **Installation** section to remove the bottle. Conditioning the ferrofluid with the clear carrier liquid is a time consuming and somewhat tricky process, so we have arranged for pre-mixed bottles to be purchased through Concept Zero studios. This is not a stock item, and you will need to let the proprietor know that the replacement is for the *Nano* exhibition. Contact information can be found in the **Reference** section.

To replace any of the graphics, remove the screw at the outside corner of any of the front table legs using a #2 Phillips screwdriver. A thin rod can be inserted into these holes and used to push the graphic up out of its recess in the tabletop. Double-stick tape the new graphic into the recess, and replace the screws.

## STATIC VS. GRAVITY

If the disks no longer spin freely, check first to see that nothing is lodged between the stand and the disk. If this area is clear, the bearings may need replacing. Refer to the assembly instructions found in the **Installation** section to remove the spinning disk and bearings. Replace the bearings if necessary. Replacement parts are listed in the **Reference** section.

If the small beads no longer “float” within the disk, they have lost their static charge. Moisture from humidity or improper cleaning are the most likely culprits, and it necessitates a thorough cleaning and drying of the entire disk. Refer to the assembly instructions found in the **Installation** section to remove the disk. Using masking tape, tape the disk from front to back in a few places to prevent the beads from falling out, and remove the eight bolts that hold the disk together with a #2 Phillips screwdriver and an 11/32” wrench. Remove the tape and CAREFULLY pour the beads into an oven-safe dish (or simply order new beads: ordering information is found in the **Reference** section). Wipe all surfaces of the disassembled disks and O-rings with denatured alcohol. Place the beads, O-rings, and disk parts (still disassembled) into an oven at a VERY low temperature (130° is ideal) for about fifteen minutes to get rid of any moisture. Reassemble the pieces while still hot, taking care not to touch any of the “inside” surfaces of the disk. Follow the instructions found in the **Installation** section to install the disk back onto the stand.

To replace the graphic, remove the screw at the outside corner of either of the front table legs using a #2 Phillips screwdriver. A thin rod can be inserted into these holes and used to push the graphic up out of its recess in the tabletop. Double-stick tape the new graphic into the recess, and replace the screws.

## I SPY NANO INTERACTIVES

To replace any of the flip cards, remove one of the mounting blocks using a #2 Phillips screwdriver. Slide the damaged flip card off of the rod, and replace with the new card. Replace the mounting block.

To replace the squeeze bottle or any part of the nozzle, remove the bottle as if you were changing the cotton ball (see detailed instructions in the **Routine Upkeep** portion of this section). Remove the bottle, and unscrew the nozzle using a 3/4” socket. If replacing the bottle, the cap of the new bottle will need a 17/32” hole drilled in the center of the cap (see the old cap as an example, and take care as the soft plastic tends to grab as it is being drilled).

Reassemble the bottle, and remount to the attached table. Part numbers for the bottle, nozzle, and brass nut can be found in the **Reference** section.

To service the ringtone found in the “Computer Chip” interactive, remove the panel underneath the attached table. Adjust the volume, and check to see that the power supply is plugged in and all of the electrical connections are tight. If nothing seems amiss, the repair may involve a basic knowledge of wiring and soldering. Wiring diagrams and replacement part numbers are found in the **Reference** section. Remove the Computer Chip graphic with a #2 Phillips screwdriver and check the speaker and solder joints. Re-solder the joints or replace the speaker if necessary, and reinstall the graphic.

To replace the Blue Morpho butterfly case, remove the acrylic cover using a #2 Phillips screwdriver. Lift the old case out and replace with the new. Reinstall the cover. It may be necessary to move the LEDs lighting the butterfly. To do this, remove the panel underneath the attached table. Unplug the interactive. Unscrew the perforated aluminum panel with a #2 Phillips screwdriver, and pry the LEDs off using a razor blade (ordering new thermal tape may be necessary to re-attach the LEDs to the panel). Reposition the LEDs by lightly sticking them to the panel. Plug the interactive back in, and check the appearance of the lighting by holding the panel in its final position and pressing the interactive button. Unplug and repeat if necessary. When satisfied, press the LEDs firmly to the panel and reassemble. Ordering information for the butterfly case and the thermal tape can be found in the **Reference** section.

## BALANCE OUR NANO FUTURE

If there is a problem with the tipping mechanism, first adjust the counterweight by following the instructions in the **Installation** section. If this does not solve the problem, gently lift the tippy platform and make sure it is still being held firmly on the bearing. If there is any vertical play to the platform, use a 5/23” Allen wrench to loosen the uppermost shaft collar underneath the carpeted panels. Hold the shaft collar and bronze bushing firmly against underside of the bearing, retighten the shaft collar, and recheck for vertical play. If there is no play to the tippy platform and there is still a problem with the tipping mechanism, the problem may be worn bushings or bearings. Use a 5/32” Allen wrench to loosen all of the shaft collars under the carpeted panels and remove the counterweight, shaft collars, and bushing from the shaft. Lift the tippy platform and shaft up off of the bearing, wipe clean and examine all parts for wear, and replace any worn parts if necessary. Examination and replacement of the bearing may also be necessary. To remove the bearing, use a 7/16” wrench and socket to loosen and remove the four bolts from the steel bearing housing at the center of the carpeted panels. Lift the steel

cover off of the housing, and remove the bearing from the housing. Examine and replace if necessary. Reverse the steps to reassemble the Tippy Table. Replacement parts are listed in the **Reference** section.

To replace the graphic, remove the screw at the outside corner of any of the table legs using a #2 Phillips screwdriver. A thin rod can be inserted into these holes and used to push the graphic up out of its recess in the tabletop. Double-stick tape the new graphic into the recess, and replace the screws.

### VERTICAL PANELS AND ATTACHED TABLES

To replace any of the flip cards, remove one of the mounting blocks using a #2 Phillips screwdriver. Slide the damaged flip card off of the rod, and replace with the new card. Replace the mounting block.

To replace any of the graphics, locate a small hole in the underside of the table attached to the vertical panel under the appropriate graphic. A thin rod can be inserted into these holes and used to push the graphic up out of its recess in the tabletop. Double-stick tape the new graphic into the recess.

### TABLES

Use a thin flathead screwdriver to pry the old graphic out of its recess. Take care not to mar the tabletop.

Often the graphic will pop free from the mounting tape, leaving the tape unharmed and still affixed to the

tabletop. If this is the case, make sure the tape is still tacky, use a utility knife to cut out any small wrinkles that may have occurred in the tape when removing the old graphic, and simply drop the new graphic into place. Press firmly on the graphic to make sure the mounting tape fully adheres to the graphic.

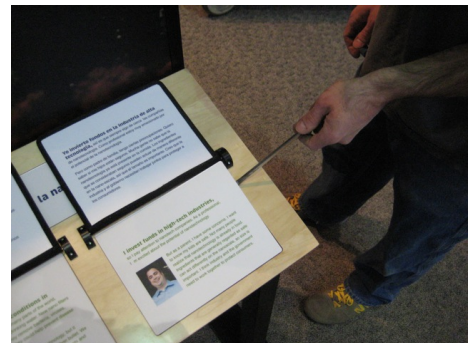



If the old mounting tape is unusable for any reason, use a utility knife to cut out any wrinkles in the old mounting tape. Lay a new strip of tape above or below the old tape, drop the new graphic in place, and press firmly to make sure the mounting tape fully adheres to the graphic.

## VERTICAL PANELS

Tilt the large upright graphic back until it is almost horizontal. The table side should be facing upwards. Place two of the stools underneath the frame (not underneath the graphic) for support.



Use a #2 Phillips screwdriver or a drill with the appropriate bit to undo the three black screws on each side of the graphic.



When all the screws are out, remove the plywood cap at the top of the graphic.



Remove the honeycomb spacer from the center of the graphic. CAUTION: Don't attempt to change the graphic with the spacer in place, as the new graphic will be scratched by the metal frame. When the spacer has been removed, pull the old graphic out and replace with the new graphic. Slide the spacer back in, reattach the plywood cap, and stand the graphic upright.



Once the graphic is upright make sure that the top edges of the graphics are being overlapped by the metal frame: there is a certain amount of flex to the frame and occasionally the top edge of the graphic will pop free during installation. Pressing the top edge of the graphic in place and pulling down firmly of the top crosspiece of the frame will remedy this problem.



### AD LABEL AND BRAILLE INSTALLATION

Installing the Braille, Audio Description, and QR code labels is as easy as peel-and-stick. Simply remove the backing and adhere the label in the correct spot. The “MiniEx\_graphics\_03\_05\_AD” file in the digital resources or the “AD Label and Braille Installation” graphics packet indicates installation areas with a circled to help you with placement.

### READING TABLE

To replace the graphic, remove the screw at the inside-most corner of the table legs underneath the graphic using a #2 Phillips screwdriver. A thin rod can be inserted into this hole and used to push the graphic up out of its recess in the tabletop. Double-stick tape the new graphic into the recess, and replace the screws.

### SEATING AREA

The covers of the sofa and the armchair are removable, machine washable (hang to dry), or in the case of permanent stains, replaceable. Additional care instructions can be found at [www.ikea.com](http://www.ikea.com), and ordering information can be found in the **Reference** section.

# REFERENCE

This section contains suggested layouts, component dimensions, off-the-shelf replacement part numbers, wiring diagrams, and MSDS information.

## SUGGESTED LAYOUTS

*Nano's* modular design allows for flexible configurations and layouts. These suggested layouts are just a few possibilities.

SQUARE (20' X 20')



RECTANGULAR (40' x 10')

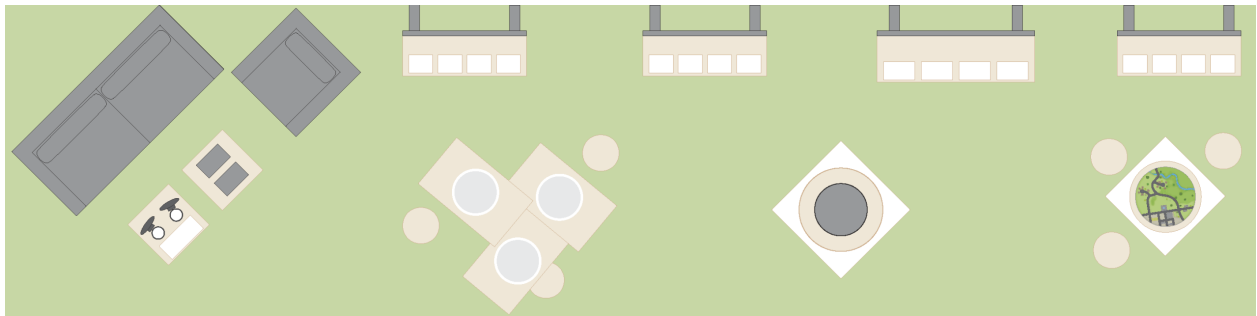

CORNER (35' x 20')



## COMPONENT DIMENSIONS

- Small, Smaller Nano  
64"W x 59"D x 45"H
- Static vs. Gravity  
23"W x 23"D x 37"H
- Build a Giant Carbon Nanotube  
38"W x 38"D x 31½"H
- Balance Our Nano Future  
33"W x 33"D x 29"H
- Vertical Panel and Attached Table (3)  
47½"W x 26½"D x 83"H
- I Spy Nano Interactive  
60½"W x 28¼"D x 83"H
- Reading Table  
23"W x 23"D x 18"H
- Sofa  
81"W x 37"D x 31½"H
- Armchair  
36"W x 37"D x 31½"H
- Stools (7)  
16"W x 16"D x 18"H

## REPLACEMENT PARTS

The following is a complete list of the off-the-shelf items contained in this exhibition. For the sake of space and because of their widespread availability, items such as bolts, nuts, washers, etc. have not been listed.

### SMALL, SMALLER, NANO

- 32oz narrow mouth bottle. McMaster-Carr, [www.mcmaster.com](http://www.mcmaster.com), item #5782T66
- 4" dia acrylic tubing. McMaster-Carr, [www.mcmaster.com](http://www.mcmaster.com), item #8486K377
- ¼"-20 threaded rod (cut to 15¼"). McMaster-Carr, [www.mcmaster.com](http://www.mcmaster.com), item #93250A029
- ½" tubing (cut to 12¾"). McMaster-Carr, [www.mcmaster.com](http://www.mcmaster.com), item #89895K29
- ¾" x 1" magnet. Applied Magnets, [www.magnet4less.com](http://www.magnet4less.com), model#ND049  
This is the magnet inside the black delrin wand. Replacement wands are custom made and can be fabricated by any machine shop.
- Magnetite Sand. Advent Energy Technologies, [www.magnetitewater.com](http://www.magnetitewater.com), (801) 226-7589  
When ordering, you must specify coarse (1-2mm diameter) particles.
- Magnetite Powder (99% Fe<sub>3</sub>O<sub>4</sub>). [www.ChemicalStore.com](http://www.ChemicalStore.com), product code FE304M1
- 32oz ferrofluid display bottle. Concept Zero, [www.czferro.com](http://www.czferro.com)  
This display bottle is not a stock item. You must contact Concept Zero and let them know that you want a replacement ferrofluid display for the *Nano* Exhibition.
- Table leg end caps. Outwater Plastics, [www.outwatercatalogs.com](http://www.outwatercatalogs.com), part #S50-6416BK

### STATIC VS. GRAVITY

- 1/16" dia. Delrin balls (1000 total). McMaster-Carr, [www.mcmaster.com](http://www.mcmaster.com), item #9614K5
- ⅜" dia Delrin balls (20 total). McMaster-Carr, [www.mcmaster.com](http://www.mcmaster.com) item #9614K58
- ¼" Sealed flanged ball bearing. McMaster-Carr, [www.mcmaster.com](http://www.mcmaster.com), item #6384K342
- ¼" Shaft Collar. McMaster-Carr, [www.mcmaster.com](http://www.mcmaster.com), item #6435K12
- 7½" dia O-ring. McMaster-Carr, [www.mcmaster.com](http://www.mcmaster.com), item #9452K363
- ¼" shaft. McMaster-Carr, [www.mcmaster.com](http://www.mcmaster.com), item #6061K412  
Shaft is press-fit into custom mounting plate.
- Table leg end caps. Outwater Plastics, [www.outwatercatalogs.com](http://www.outwatercatalogs.com), part #S50-6416BK

## BUILD A GIANT CARBON NANOTUBE

- Carbon atom building set. Popfoam, [www.popfoam.com](http://www.popfoam.com), (360) 241-8590  
This is a custom building set. Call to inquire about price and availability.
- Table leg end caps. Outwater Plastics, [www.outwatercatalogs.com](http://www.outwatercatalogs.com), part #S50-6416BK

## I SPY NANO INTERACTIVES

- $\frac{1}{8}$ " stainless steel rod (cut to  $12\frac{3}{4}$ "). McMaster-Carr, [www.mcmaster.com](http://www.mcmaster.com), item #7972A258
- 8oz wide mouth squeeze bottle. U.S. Plastic Corp., [www.usplastic.com](http://www.usplastic.com), item #70146
- 90°  $\frac{1}{4}$ " barbed elbow. McMaster-Carr, [www.mcmaster.com](http://www.mcmaster.com), item #5372K311
- Brass locknut. McMaster-Carr, [www.mcmaster.com](http://www.mcmaster.com), item #4429K121
- 36mm speaker. Allied Electronics, [www.alliedelec.com](http://www.alliedelec.com), stock #623-0006
- TecMp3 player with CF memory card. Technovision, <http://technovision.com>
- Pushbutton. Suzo-Happ, [na.suzohapp.com](http://na.suzohapp.com), item #D54-0004-20
- 12VDC 500 mA power supply. McMaster-Carr, [www.mcmaster.com](http://www.mcmaster.com), item #70235K68
- Cool white Rebel Star LED. Luxeon Star LEDs, [www.luxeonstar.com](http://www.luxeonstar.com), part #MR-WC100-20S
- Pre-cut thermal adhesive tape. Luxeon Star LEDs, [www.luxeonstar.com](http://www.luxeonstar.com), part #LXT-S-12
- 8Ω resistor. Allied Electronics, [www.alliedelec.com](http://www.alliedelec.com), stock #895-4476
- $\frac{1}{2}$ " 6-32 ceramic standoff. McMaster-Carr, [www.mcmaster.com](http://www.mcmaster.com), item #94335A125
- $\frac{1}{2}$ " nylon spacer. McMaster-Carr, [www.mcmaster.com](http://www.mcmaster.com), item #94639A455
- Blue Morpho butterfly case. Butterfly Utopia, [ButterflyUtopia.com](http://ButterflyUtopia.com), (718) 302-1902  
This is a custom item. You must specify that the Blue Morpho be mounted vertically and flat against the back of the case.
- Brown costume fur. Hancock Fabrics, [www.hancockfabrics.com](http://www.hancockfabrics.com), SKU #2867125
- $\frac{3}{8}$ "-16 levelers. Outwater Plastics, [www.outwatercatalogs.com](http://www.outwatercatalogs.com), part #R33-601BK
-

## BALANCE OUR NANO FUTURE

- 16mm bronze flanged sleeve bearing. McMaster-Carr, [www.mcmaster.com](http://www.mcmaster.com), item #6659K33
- 16mm shaft collar. McMaster-Carr, [www.mcmaster.com](http://www.mcmaster.com), item #57445K71
- 16mm ball joint bearing. McMaster-Carr, [www.mcmaster.com](http://www.mcmaster.com), item #2995K36
- 16mm shaft. McMaster-Carr, [www.mcmaster.com](http://www.mcmaster.com), item #1482K27  
Shaft is welded to custom mounting plate.
- Carpet. Seestedt's Carpet & Linoleum Co., [www.seestedtscarpet.com](http://www.seestedtscarpet.com), (651) 224-5474.  
Vitality Ebony Carpet.
- Tree blocks. Haba, [www.haba.de](http://www.haba.de)  
These are manufactured by Haba and are widely available at toy stores and online.
- Car blocks. Maple Landmark Woodcraft, [www.maplelandmark.com](http://www.maplelandmark.com), (800) 421-4223  
The cars are part of Maple Landmark's "Mites" line of vehicles.
- Building blocks. Maple Landmark Woodcraft, [www.maplelandmark.com](http://www.maplelandmark.com), (800) 421-4223  
This is a custom set of blocks, call to inquire about cost and availability.
- Table leg end caps. Outwater Plastics, [www.outwatercatalogs.com](http://www.outwatercatalogs.com), part #S50-6416BK

## VERTICAL PANELS AND ATTACHED TABLES

- $\frac{1}{8}$ " stainless steel rod (cut to 10"). McMaster-Carr, [www.mcmaster.com](http://www.mcmaster.com), item ##7972A258
- $\frac{3}{8}$ "-16 levelers. Outwater Plastics, [www.outwatercatalogs.com](http://www.outwatercatalogs.com), part #R33-601BK

## SEATING/MISCELLANEOUS

- Karlstad armchair, sivik dark gray. IKEA, [www.ikea.com](http://www.ikea.com), article #298.403.89
- Karlstad armchair cover, sivik dark gray. IKEA, [www.ikea.com](http://www.ikea.com), article #901.184.44
- Karlstad sofa, sivik dark gray. IKEA, [www.ikea.com](http://www.ikea.com), article #298.405.20
- Karlstad sofa cover, sivik dark gray. IKEA, [www.ikea.com](http://www.ikea.com), article #901.187.12
- Stools, maple seat with black frame. Alfax, [alfaxfurniture.com](http://alfaxfurniture.com), item #D57023
- Gecko puppet. The Puppet Store, [www.thepuppetstore.com](http://www.thepuppetstore.com), #NP8203
- Blue Morpho butterfly puppet. The Puppet Store, [www.thepuppetstore.com](http://www.thepuppetstore.com), #NP8244



## READING TABLE

Titles are subject to availability.

- *Alice in Nanoland*, by Leigha Horton and Stephanie Long  
Free download available at [www.nisenet.org](http://www.nisenet.org), hard copy available at [www.lulu.com](http://www.lulu.com)
- *Careers in Nanotechnology (Cutting-Edge Careers)*, by Corona Brezina  
ISBN-10: 1404209557    ISBN-13: 978-1404209558  
Widely available at bookstores and online.
- *How Small is Nano?*, by Catherine McCarthy, Rae Ostman, Emily Maletz, and Stephen Hale  
ISBN-10: 0578001977    ISBN-13: 978-0578001975  
Free download available at [www.nisenet.org](http://www.nisenet.org), hard copy available at [www.lulu.com](http://www.lulu.com)
- *Is That Robot Real?*, by Catherine McCarthy, Rae Ostman, Emily Maletz, and Stephen Hale  
ISBN-10: 0578001969    ISBN-13: 978-0578001968  
Free download available at [www.nisenet.org](http://www.nisenet.org), hard copy available at [www.lulu.com](http://www.lulu.com)
- *Micro Machines: Ultra-Small World of Nanotechnology Science Frontiers*, by David Jefferis  
ISBN-10: 0778728730    ISBN-13: 978-0778728733  
Widely available at bookstores and online.
- *Nanotechnology for Dummies*, by Richard Booker and Earl Boysen  
ISBN-10: 0764583698    ISBN-13: 978-0764583681  
Widely available at bookstores and online.
- *Nanotechnology Demystified*, by Linda Williams and Dr. Wade Adams  
ISBN-10: 0578001977    ISBN-13: 978-0578001975  
Widely available at bookstores and online.
- *Science on the Edge: Nanotechnology*, by Dianne Maddox  
ISBN-10: 1410305309    ISBN-13: 978-1410305305  
Widely available at bookstores and online.
- *Nanotechnology (Cool Science)*, by Rebecca L. Johnson  
ISBN-10: 0822557738    ISBN-13: 978-0822557739  
Widely available at bookstores and online.
- *What's Smaller than a Pygmy Shrew?*, by Robert E. Wells  
ISBN-10: 0807588385    ISBN-13: 978-0807588383  
Widely available at bookstores and online.
- Table leg end caps. Outwater Plastics, [www.outwatercatalogs.com](http://www.outwatercatalogs.com), part #S50-6416BK

## WIRING DIAGRAMS

### I SPY NANO, BLUE MORPHO BUTTERFLY INTERACTIVE

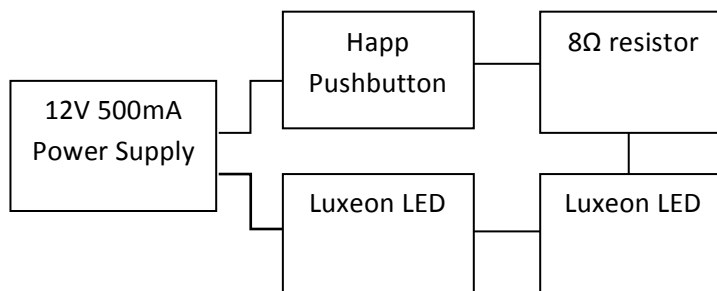

### I SPY NANO, COMPUTER CHIP INTERACTIVE

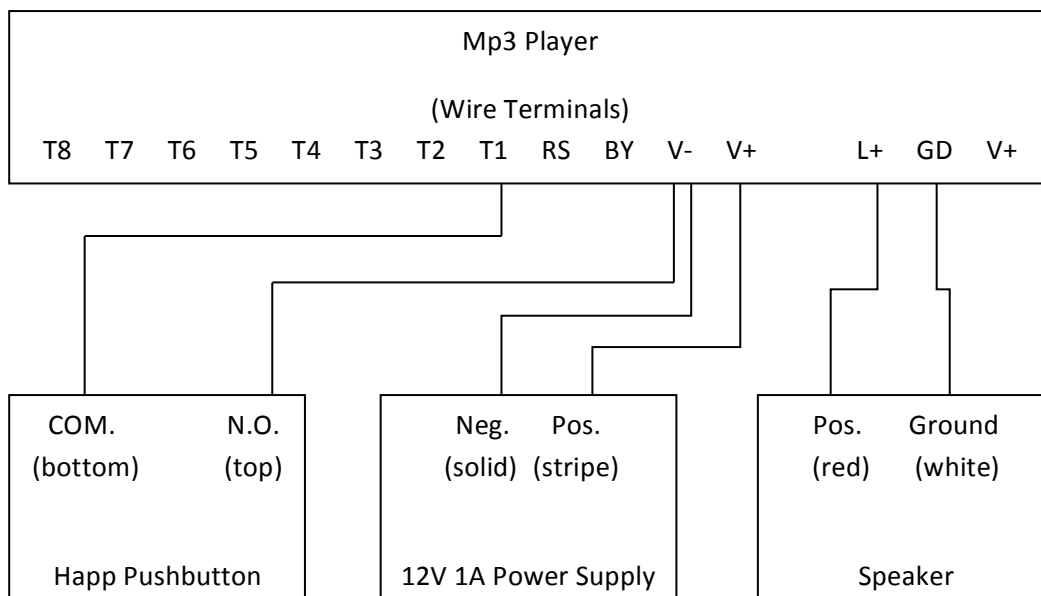

## MSDS INFORMATION

### MSDS - MAGNETITE POWDER

## Synthetic Magnetite (Black Iron Oxide)

### MATERIAL SAFETY DATA SHEET

#### SECTION I: PRODUCT IDENTIFICATION

**SUPPLIER'S NAME:** chemicalstore.com, miniscience Inc.

**SUPPLIER'S ADDRESS:** 1059 Main Avenue, Clifton, NJ 07011

**TELEPHONE NUMBER:** 973-405-6248

For Chemical Emergency Spill, Leak, Fire, Exposure or Accident call CHEMTREC Day or Night Domestic North American (800) 424-9300 International, Call (703) 527-3887 (collect calls accepted)

**PRODUCT NAME:** Synthetic Iron Oxide Black **TRADE NAME:** Iron Oxide Black

**GRADES/CODES:** FE3O4M1 **FORMULA:** Fe3O4

**SYNONYMS:** Magnetite

**HMIS RATINGS:** H: 0 F: 0 R: 0 PP: SEE "SECTION VIII"

#### SECTION II: HAZARDOUS INGREDIENTS

INGREDIENT (CAS #)	%	OSHA PEL	ACGIH TWA
Iron Oxide* 1309-38-2	90-94	10 MG/M3	5 MG/M3

**REGULATORY INFORMATION:** according to osha 29 cfr i 1910.1200 iron oxide is not "extremely hazardous or toxic". Values are given for permissible exposure limits and threshold values for dusting and fumes. There are no toxic chemicals under sara title iii section 313. This product is listed on tsca inventory. This product has no reportable quantities (rq) under cercla. It is not considered a hazardous waste under cercla or rcra. This product is not listed on the hazardous materials hm 181.

Iron oxide does not appear on the hazardous substances list for nj, ma, or pa.

**CARCINOGENICITY:** this product is not listed as a carcinogen by ntp, iarc, osha or acgih as synthetic iron oxide black.

**OSHA:** occupational safety & health administration; **tsca:** e.p.a. toxic substances control act; **cercla:** comprehensive environmental response compensation and liability act; **ntp:** national toxicology program; **iarc:** international agency for research on cancer; **acgih:** american conference of governmental industrial hygienists; **rcra:** resource conservation and recovery act - r e.p.a.

#### SECTION III: PHYSICAL DATA

**APPEARANCE/ODOR:** Black Powder/Odorless

**BOILING POINT:** Not Applicable

**BULK DENSITY:** 600-800 KG/M3 @ 68 F (20 C)

**EVAPORATION RATE:** Not Applicable

**FREEZING POINT:** Not Applicable

**MELTING POINT:** 1594 C

**PH:** 4 - 8 @ 50 G/L Water In Aqueous Suspension

**SPECIFIC GRAVITY:** Approx 5

**SOLUBILITY IN WATER:** Slight

**VAPOR DENSITY:** N/A

**VAPOR PRESSURE:** N/A

**MOLECULAR WEIGHT:** 231.53

## **SECTION IV: FIRE & EXPLOSION HAZARD DATA**

**NFPA HAZARD CLASSIFICATION:** Health Hazard: 0 Fire Hazard: 0 Reactivity: 0

**FLASH POINT:** NOT APPLICABLE

**FLAMMABILITY LIMITS IN AIR BY VOLUME:** NOT APPLICABLE

**FLAMMABILITY CLASSIFICATION:** NOT APPLICABLE

**D.O.T. CLASSIFICATION:** NOT REGULATED; NOT FLAMMABLE

**EXTINGUISHING MEDIA:** use appropriate extinguishing media for the combustible material involved in the fire.

**SPECIAL FIREFIGHTING PROCEDURES:** FIREFIGHTERS SHOULD WEAR SELF-CONTAINED BREATHING APPARATUS.

**UNUSAL FIRE & EXPLOSION HAZARDS:** NONE.

\*SEE SECTION V11 REGARDING STORAGE OF MATERIAL

## **SECTION V: REACTIVITY DATA**

**STABILITY:** STABLE

**CONDITIONS TO AVOID:** excessive temperatures greater than 176° f (80°c)

**INSTABILITY CONDITIONS:** excess temperatures. at temperatures greater then 176°f (80°c), product may become unstable and auto oxidize into fe2O3.

**INCOMPATIBILITY (MATERIALS TO AVOID):** not known

**HAZARDOUS DECOMPOSITION OR BY PRODUCTS:** none

**HAZARDOUS POLYMERIZATION:** will not occur

temperatures greater than 176 f (80 c) may cause this product to become unstable (slowly auto oxidize) which generates some additional heat. under certain circumstances this heat may be sufficient to cause combustible material to ignite. do not store near sources of heat, or near flammable or combustible materials.

## **SECTION VI: HEALTH HAZARD DATA: EFFECTS OF OVEREXPOSURE**

**Inhalation health risks & symptoms of exposure:** sneezing, coughing, runny nose if exposed to extreme dust clouds.

**Skin & eye contact health risks & symptoms of exposure:** iron oxide is essentially non-irritating to the skin and eyes. (see acute/chronic). Silica amorphous in larger quantities is a slight eye irritant in laboratory animals; mild rash may develop on skin.

**Ingestion health risks & symptoms of exposure:** iron oxide is essentially non-toxic.

**Health hazards (acute / chronic):** prolonged inhalation of iron oxide dust (6 to 10 years) is known to produce a condition called "siderosis". On x-rays it appears to be a benign pneumoconiosis and is not associated with pulmonary fibrosis or disability unless there is concurrent exposure to other fibrosis-producing materials such as silica.

**CARCINOGENICITY:** ntp, irac, osha, acgih; not listed. See notification "section ii", under "carcinogenicity".

**TERATOGENICITY:** none known. Lco; graeter than 1000 mg/1 golden orfe (leuciscus idus)

**MUTAGENICITY:** NON KNOWN

**TOXICOLOGICALLY SYNERGISTIC PRODUCTS:** NON KNOWN

**MEDICAL CONDITIONS AGGRAVATED BY EXPOSURE:** individuals with pre-existing lung diseases may have increased susceptibility if tlv are exceeded.

**EMERGENCY & FIRST AID PROCEDURES.**

**INHALATION:** iron oxide is not known to produce any harmful effects if inhaled, however, if victim complains of dizziness move to fresh air immediately.

**SKIN CONTACT:** wash with water and a mild soap.

**EYES:** flush eyes with large amounts of water for about fifteen minutes, should an irritation develop contact a physician.

**INGESTION:** iron oxide is not known to be fatal. Give person water to drink and induce vomiting. Check with a physician.

**\*\*\*NOTIFICATION:** NEVER GIVE ANYTHING - NOT EVEN WATER TO AN UNCONCIOUS PERSON - GET MEDICAL ATTENTION IMMEDIATELY.

## **SECTION VII: PRECAUTIONS FOR SHIPPING/STORAGE/HANDLING USE SPILL OR LEAK PROCEDURES**

**SPILL PROCEDURES:** vacuum or use wet clean-up procedures and place waste material in closed containers. Avoid excessive dusting.

**WASTE DISPOSAL METHOD:** material which can not be recycled into work process should be landfilled in accordance with federal, state, and local regulations.

**HANDLING/STORAGE PRECAUTIONS:** shelf life of iron oxide is unlimited. Store in a cool, dry place. Keep away from food and beverages. Do not store near strong oxidizers.

\* temperatures greater than 176 f (80 c) may cause this product to become unstable (slowly auto oxidize) which generates some additional heat. Under certain circumstances this heat may be sufficient to cause combustible material to ignite. Do not store near sources of heat, or near flammable or combustible materials.

## **SECTION VIII: special protection information/control measures**

**RESPIRATORY PROTECTION:** ambient concentrations in the work area should be monitored and if the recommended exposure limit is exceeded, or concentrations up to 10 times the exposure limit for niosh/msha, use approved respirators.

**VENTILIATION:** use local ventilation to maintain air levels below the recommended exposure limits if dusting is a problem.

**PROTECTIVE GLOVES:** rubber, cloth or plastic gloves are recommended to reduce skin contact where appropriate for work conditions.

**EYE PROTECTION:** safety glasses are recommended.

**WORK/HYGENIC PRACTICES:** eye wash stations and washing facilities are recommended for employees using product. Employees should wash their hands/face before eating, drinking or using tobacco products.

## **SECTION IX: TRANSPORTATION DATA**

**D.O.T. SHIPPING NAME:** NOT REGULATED.

**HAZARD CLASS:** NOT APPLICABLE

**IDENTIFICATION NUMBER:** NOT APPLICABLE

**PACKING GROUP:** NOT APPLICABLE

**LABEL:** SYNTHETIC IRON OXIDE BLACK

## **SECTION X: DISCLAIMER**

All information presented in this material safety data sheet is given in good faith and is based upon sourced and tests considered to be reliable but they can not be guaranteed. It is the user's full responsibility to accept risk for the safety, handling, storage, use and toxicity of this product, as well as to determine the suitability of the product for a specific purpose.

Therefore all risks must be assumed by the user. No warranties are expressed or implied on the accuracy of the information. Pmet, inc. Assumes no legal responsibility for use or reliance upon these data.

February 2007

## MSDS - EFH1 FERROFLUID

March 18, 2009

### MATERIAL SAFETY DATA SHEET

#### SECTION I: PRODUCT IDENTIFICATION

MANUFACTURER'S NAME: Ferrotec (USA) Corporation  
ADDRESS: 33 Constitution Drive

Bedford, N.H. 03110  
TELEPHONE: (603) 472-6800  
EMERGENCY ONLY TELEPHONE: (800) 424-9300 (Domestic)

(703) 527-3887 (For International)  
CHEMICAL NAME: Proprietary Product  
TRADE NAME & SYNONYMS: EFH Series  
CHEMICAL FAMILY: Colloidal Dispersion  
FORMULA: Mixture

#### SECTION II: COMPONENTS

The precise composition of this mixture is proprietary information. A more complete disclosure will be provided to a physician or nurse in the event of a medical emergency.

Magnetite: 3-15 % by volume  
Oil Soluble Dispersant: 6-30 % by volume  
Carrier Liquid: 55-91 % by volume

#### SECTION III: CHEMICAL AND PHYSICAL PROPERTIES

Boiling Point (°F): 401-491  
Specific Gravity: 0.92 to 1.47  
Vapor Pressure (mm Hg.): 1 at 100°F  
Percent Volatile by Volume: 55-91 %  
Vapor Density (AIR = 1): 6.4  
Solubility in Water: Negligible  
Evaporation Rate at: <0.1  
Appearance & Odor: Black liquid, mild odor

MSDS: EFH SERIES FERROFLUID Page 1 of 4

#### SECTION IV: FIRE AND EXPLOSION HAZARD AREA

Flash Point (°F): 160°

Method: TCC

Flammable Limits: uel: 0.6

lel : 7.0 at 77°F

Extinguishing Media: CO<sub>2</sub>, Foam, dry chemical, water spray.

Special Fire Fighting Procedure: Avoid smoke inhalation. Water spray may

cause frothing.

Unusual Fire and Explosion Hazard: None

#### SECTION V: HEALTH HAZARD AREA

Threshold Limit Value:

5mg/m<sup>3</sup> for oil mist in air (OSHA

Regulations 29 CFR 1910-1000)

Effects of Overexposure:

No experience with overexposure.

Prolonged or repeated contact with skin or eye contact may cause irritation. Inhalation of mist or vapor at high temperature may irritate respiratory passages.

Emergency and First Aid Procedures:

Skin Contact:

Wash with soap and water.

Eyes:

Flush with water and consult a physician for treatment.

Inhalation of Smoke or Mist:

Move to fresh air and refer to physician for treatment.

Ingestion:

The material has minimal toxicity, but fluid aspirated into the lungs during ingestion could cause severe pulmonary injury.

You should not induce vomiting and should seek medical attention if the material is ingested.

MSDS: EFH SERIES FERROFLUID

Page 2 of 4

## SECTION VI: REACTIVITY DATA

### Stability:

Unstable [ ] Conditions to Avoid: Pyrolysis

Stable [x]

### Incompatibility (materials to avoid):

Strong oxidizing materials, heat, and flame.

### Hazardous Decomposition Products:

Burning may produce carbon monoxide and nitrogen oxides.

### Hazardous Polymerization:

May Occur [ ] Will Not Occur [x]

## SECTION VII: SPILL OR LEAK PROCEDURES

### Steps to be taken in case material is released or spilled:

Remove free liquid. Add absorbent (sand, earth, sawdust) to spill area. After removing absorbent, wash surface with soap and water to reduce possible slipping hazard.

### Waste Disposal Method:

Consult federal, state and local regulations applicable to disposal of waste oils.

## SECTION VIII: SPECIAL PROTECTION INFORMATION

### Respiratory Protection (Specify Type):

None required unless smoke, mists, or vapors are produced.

### Ventilation:

No special ventilation required.

### Protective Gloves:

If required to prevent prolonged or repeated skin contact.

### Eye Protection:

Safety glasses, if splash is possible.

### Other Protective Equipment:

Not needed.

## SECTION IX SPECIAL PRECAUTIONS

MSDS: EFH SERIES FERROFLUID



Page 3 of 4

Precautions to be taken in handling and storing:

Ordinary care in handling chemicals. Wash hands after handling.

Other Precautions:

Avoid contamination of tobacco products. Users should be aware that a very small

percentage of the population may display unexpected allergic skin reactions to

otherwise innocuous industrial chemicals and raw material.

#### SECTION X: TRANSPORT INFORMATION

U.S. DOT Bulk

Shipping Description: Not regulated

U.S. DOT Non-Bulk

Shipping Description: Not regulated

IMDG Code

Shipping Description: Not regulated

ICAO Shipping Description: Not regulated

ADR/RID Hazard Class: Not regulated

#### SECTION XI: COMMENTS

\*

This product DOES NOT contain any materials considered to be carcinogenic by any recognized sources.

\*\*

This material is not sold for use in products for which prolonged contact with skin or implantation in the human body is intended. Ferrotec (USA) Corporation does not recommend this material as safe and effective for such uses and assumes no liability for any such use.

\*\*\*

This product does not contain any chemical subject to the reporting requirements of Section 313 of Title III of the Superfund Amendment and Reauthorization Act of 1986 and 40 CFR Part 372.

MSDS: EFH SERIES FERROFLUID

Page 4 of 4

## MSDS - CZFERRO GEN3 LIQUID

### Material Safety Data Sheet

May be used to comply with OSHA's Hazard Communication Standard, 29 CFR 1910 1200. Standard must be consulted for specific requirements.

### U.S. Department of Labor

Occupational Safety and Health Administration  
(Non-Mandatory Form)  
Form Approved  
OMB No. 1218-0072

IDENTITY CZFerro Gen3 SL	<i>Note: Blank spaces are not permitted. If any item is not applicable or no information is available, the space must be marked to indicate that.</i>
--------------------------	---

#### Section I

Manufacturer's name: Concept Zero	Emergency Telephone Number; 973-493-5253
Address; (Number, Street, City, State and ZIP Code)	Telephone Number for Information; 973-493-5253
33 1/2 Main Street	Date Prepared n/a
Bloomington, NJ 07403	Signature of Preparer (optional)

#### Section II—Hazardous Ingredients/Identity Information

Hazardous Components (Specific Chemical Identity, Common Name(s))	OSHA PEL	ACGIH TLV	Other Limits Recommended	% (optional)
The precise formula of this liquid is proprietary information. A more complete disclosure will be provided to a physician or nurse in the event of a medical emergency.				
Water: >99% by volume.				
Water soluble additive: <1% by volume.				

#### Section III—Physical/Chemical Characteristics

Boiling Point	100C	Specific Gravity (H <sub>2</sub> O = 1)	n/a
Vapor Pressure (mm Hg)	n/a	Melting Point	n/a
Vapor Density (AIR = 1)	n/a	Evaporation Rate (Butyl Acetate = 1)	n/a
Solubility in Water n/a			
Odorless and colorless			

#### Section IV—Fire and Explosion Hazard Data

Flash Point (Method Used) None	Flammable Limits	LEL N/A	UEL N/A
Extinguishing Media None			
Special Fire Fighting Procedures :Non-Flammable			
Unusual Fire and Explosion Hazards :None			
(Reproduce locally)			OSHA 174 Sept. 1985

#### Section V—Reactivity Data

Stability	Stable		
Incompatibility (Materials to Avoid)			
Hazardous Decomposition or Byproducts			
Hazardous Polymerization			

Will Not Occur

**Section VI—Health Hazard Data**

Route(s) of Entry      Inhalation : N/A      Skin: Mild redness of skin and irritation      Ingestion: Drink water

Health Hazards (*Acute and Chronic*)

Hazardous to humans and domestic animals. Corrosive. Fatal if swallowed. Do not get in eyes, on skin, or on clothing. Wear goggles and rubber gloves. Do not swallow. Wash thoroughly after handling.

Carcinogenicity: N/A      NTP: N/A      IARC Monographs: N/A      OSHA Regulated : N/A

Signs and Symptoms of Exposure

Medical Conditions  
Generally Aggravated by Exposure

Emergency and First Aid Procedures: If in the eyes: Hold eye open and rinse slowly and gently with water for 15-20 minutes. Remove contact lenses. If present, after the first 5 minutes, then continue rinsing eye. Call a poison control center or a doctor for treatment advice. IF ON SKIN OR CLOTHING: Take off contaminated clothing. Rinse skin immediately with plenty of water for 15-20 minutes. Call a poison control center or doctor immediately for treatment advice. IF SLALLOWED: Call a poison control center or doctor immediately for treatment advice. Have person sip a glass of water if able to swallow. Do not induce vomiting unless told to do so by a poison control center or doctor. Do not give anything by mouth to an unconscious person.

**Section VII—Precautions for Safe Handling and Use**

Steps to Be Taken in Case Material Is Released or Spilled: Clean with soap and water.

Waste Disposal Method: Rinse out used container with water and throw away in trash. Don not reuse container.

Precautions to Be Taken in Handling and Storing: Store in a cool area 65-70 degrees F. Tightly close lid when not in use.

Other Precautions

**Section VII—Control Measures**

Respiratory Protection (*Specify Type*)

Ventilation	Local Exhaust	Special
	Mechanical ( <i>General</i> )	Other

Protective Gloves - Yes      Eye Protection - Yes

Other Protective Clothing or Equipment - N/A

Work/Hygienic Practices - N/A

# SHIPPING

The exhibition ships on 4 pallets.

Pallet	Dimensions	Weight	Total Weight
PALLET #1	48" L x 40" W x 54" H	357 LBS	
PALLET #2	48" L x 40" W x 88" H	369 LBS	
PALLET #3	48" L x 40" W x 88" H	517 LBS	
PALLET #4	72" L x 48" W x 88" H	550 LBS	<b>1793 lbs</b>

## SHIPPING MATERIALS

The following materials are used in shipping the exhibition. We recommend that you retain materials when possible, especially if you have plans to share the exhibition with other sites. By storing these materials, you can easily repack the exhibition and truck it to another location (if renting a UHaul truck or using your own, be sure you have at least an 8 ft. high clearance).

- 2" x 110 yd. packing tape (2x). Uline, [www.uline.com](http://www.uline.com), model #S-119
- 9" x 9" x 9" box (1x). Uline, [www.uline.com](http://www.uline.com), model #S-4094
- 20" x 14" x 16" box (1x). Uline, [www.uline.com](http://www.uline.com), model #S-16759
- 28" x 5½" x 38" box (2x). Uline, [www.uline.com](http://www.uline.com), model #S-4768
- 24" x 5" x 24" box (2x). Uline, [www.uline.com](http://www.uline.com), model #S-4998
- 16" x 10" x 16" box (2x). Uline, [www.uline.com](http://www.uline.com), model #S-15053
- 12" x 9" x 6" box (1x). Uline, [www.uline.com](http://www.uline.com), model #S-4406
- 24" x 36" 200lb corrugated pad (2x). Uline, [www.uline.com](http://www.uline.com), model #S-2483
- 48" x 72" 200lb corrugated pad (3x). Uline, [www.uline.com](http://www.uline.com), model #S-3960
- Kraft paper sheets 24" x 36" 800ct. (1x). Uline, [www.uline.com](http://www.uline.com), model #S-12830
- Stretch wrap (1x). Uline, [www.uline.com](http://www.uline.com), S-12899S
- 72" x 48" heat treated wood pallet (1x). Uline, [www.uline.com](http://www.uline.com), model #H-1815
- 48" x 40" wood pallet (3x). Uline, [www.uline.com](http://www.uline.com), model #H-1218
- 2" x 2" x 60" .120 edge protector (1x). Uline, [www.uline.com](http://www.uline.com), model #S-8482
- 2" x 2" x 48" .120 edge protector (3x). Uline, [www.uline.com](http://www.uline.com), model #S-2443
- 2 oz round HDPE jar (2x). U.S. Plastic Corp., [www.usplastic.com](http://www.usplastic.com), item #66413
- 15 cc dropper bottle (2x). U.S. Plastic Corp., [www.usplastic.com](http://www.usplastic.com), item #66460
- Corrupad channel (3x). Multi-Wall Packaging, [www.multiwall.com](http://www.multiwall.com)

## SHIPPING MANIFEST

OBJECT	CONTENTS	DIMENSION	WEIGHT	TOTAL#	TOTAL WEIGHT	PALLET #
		(L x W x H)	(LBS)		(LBS)	
I-Spy Vertical Panel	n/a	28.5" x 60.5 x 83"	200	1	200	#4
Vertical Panel	n/a	26.5" x 47.5" x 83"	165	3	495	1x on each: #2, #3, #4
Balance Our Nano Future	n/a	33" x 33" x 29"	95	1	95	#1
Build A Giant Carbon Nanotube	100x "Pucks", 150x "Sticks"	38" x 38" x 29"	145	1	145	#1
Sofa Box #1	1x Sofa frame, 4x cushions	29" x 19" x 72"	105	1	105	#3
Sofa Box #2	2x Sofa arms	20" x 10" x 36"	35	1	35	#4
Sofa Cover Box	1x Sofa cover	15" x 4" x 23"	10	1	10	#2
Armchair Box	1x Armchair frame, 4x cushions	36" x 21" x 37"	75	1	75	#2
Armchair Cover Box	1x Armchair cover	15" x 4" x 23"	7	1	7	#2
Stool Box	1x stool	16" x 16" x 20"	15	7	105	2x on #2, 5x on #4
Static vs. Gravity Box 1	1x Static Beads tabletop, 4x 22.5" table legs	24" x 5" x 24"	40	1	40	#1
Static vs. Gravity Box 2	2x Spinning Disks, 2x Stands, 4x bearings, 2x shaft collars	9" x 9" x 9"	10	1	10	#2
Reading Table Box	1x Reading Table tabletop, 4x 16.5" table legs, reading cards	24" x 5" x 24"	35	1	35	#1
Build A Giant Carbon Nanotube Box	100x "Pucks", 150x "Sticks", spare "Benny" fur	20" x 14" x 16"	15	1	15	#2
Small, Smaller, Nano Box 1	3x Small, Smaller, Nano tabletops	28" x 5.5" x 38"	105	1	105	#3
Small, Smaller, Nano Box 2	2x 30.5" table legs, 1x 30.5" table leg with flange, 4x 29" table legs, 3x 27.5" table legs	28" x 5.5" x 38"	55	1	55	#3
Small, Smaller, Nano Box 3	3x acrylic tubes, 3x circular plywood base, 3x triangular plywood cap, 6x magnetic wands, 9x stainless steel rod/tube assembly, 1x bleach, 1x magnetite sand, 1x magnetite powder, 2x empty glass bottles, 1x glass bottle w/ferrofluid	16" x 10" x 16"	25	1	25	#3
Tippy Table Box	4x block set, 4x tree set, 2x car set,, 1x counterweight, 2x shaft collars, 1x blue morpho butterfly puppet, 1x gecko puppet	16" x 10" x 16"	20	1	20	#3
Manuals/Books/Hardware Box	1x installation/maintenance manual, 1x signage copy, 1x marketing materials, 1x UD & accessibility guide, 1x educator guide, 1x evaluation findings, 1x contract information, 10x reading area books, exhibit hardware	12" x 9" x 6"	15	1	15	#2
Standard Pallet	n/a	48" x 40" x 5"	42	3	126	#1, #2,#3
Oversize Pallet	n/a	72" x 48" x 5"	75	1	75	#4
	PALLET #1 WEIGHT: 357 LBS					
	PALLET #2 WEIGHT: 369 LBS					
	PALLET #3 WEIGHT: 517 LBS					
	PALLET #4 WEIGHT: 550 LBS				1793 lbs	

**\*ALL EXHIBIT PIECES SHIPPED IN BOXES MUST BE WRAPPED AND PADDED**

## PALLET CONTENTS AND ILLUSTRATIONS

### PALLET #1

(48" L x 40" W x 54" H, 357 lbs)

#### **Contents:**

- Balance our Nano Future
- Build a Giant Carbon Nanotube
- 1 set Giant Carbon Nanotube pieces (in Carbon Nanotube trough)
- Static Beads Box #1
- Reading Table Box

(See Shipping Manifest for detailed contents and dimensions of boxes)

## PALLET #1 Illustrations



## **PALLET #2**

(48" L x 40" W x 88" H, 369 lbs)

### **Contents:**

- Reading Rail
- Sofa Cover Box
- Armchair Box
- Armchair Cover Box
- 2x Stool Boxes
- Static Beads Box #2
- Build A Giant Carbon Nanotube Box
- Manuals/Books/Hardware Box

(See Shipping Manifest for detailed contents and dimensions of boxes)

**NOTE: THE CARDBOARD BOX AT THE TOP OF THE STACK CONTAINS TOOLS FOR THE INITIAL INSTALL AND SHOULD NOT BE INCLUDED IN SUBSEQUENT PACKS**



## PALLET #2 Illustrations



### **PALLET #3**

(48" L x 40" W x 88" H, 517 lbs)

#### **Contents**

- Reading Rail
- Sofa Box #1
- Small, Smaller, Nano Box #1
- Small, Smaller, Nano Box #2
- Small, Smaller, Nano Box #3
- Tippy Table Box

(See Shipping Manifest for detailed contents and dimensions of boxes)

### PALLET #3 Illustrations



**PALLET #4**

(72”L x 48”W x 88”H, 550 lbs)

**Contents:**

- I-Spy Reading Rail
- Reading Rail
- Sofa Box #2
- Sofa Cover Box
- 5x Stool Boxes

(See Shipping Manifest for detailed contents and dimensions of boxes)

## PALLET #4 Illustrations



# EXHIBITION COMMITMENTS

## OWNERSHIP AGREEMENT

*Please consult your signed ownership agreement for final exact language. Below is an overview of exhibition commitments and restrictions*

### **Display and Ownership Commitment:**

- Ownership by host museums will commence upon the day the exhibition is received.
- Host museums will commit to display the mini-exhibition in its entirety for a minimum of one (1) year.
- The one (1) year required display period does not have to be contiguous; however, the exhibition must be on display for a minimum of twelve (12) months within the first twenty-four (24) months of ownership.
- If circumstances change and a host is unable to display the exhibition, host must immediately notify NISE Network Mini-Exhibition contact.
- After meeting the one-year display commitment, host may keep the exhibition on display as long as host deems appropriate.

### **During the 1 year required display period:**

- Host museums shall be responsible for all repairs, routine care, maintenance and replacements of consumable supplies.
- Host museums may modify some portions of the exhibit(s) to meet the needs of their museum floor. For example, hosts may make repairs with non-specified parts, and may add an exhibit component, additional signage, or a multimedia component.
- 

### **After the 1 year required display period is met:**

- Host museums may keep the exhibition and continue to use the exhibit(s) at their institution as they see fit.

- Host museums may choose to use or modify the exhibit(s) and components for another purpose, at their own institution.
- Host museums may lend exhibition to another suitable institution of the host museum's choosing for display to the public; the host may not tour the exhibition for a fee; host museums may charge a transportation fee to transport the exhibition to another institution. The NISE Network may be able to offer suggestions of possible locations interested in borrowing the exhibition.
- Host museum may give exhibition to another suitable institution of the host's choosing for display to the public. The NISE Network may be able to offer suggestions of possible locations interested in owning the exhibition.
- In any event, host museums will notify the NISE Net Mini-Exhibition contact of its intention for use beyond the one (1) year required display period at least four months prior to the end of the one (1) year display period.

#### **Restrictions:**

- Host museums will not remove any credit graphics on the Nano mini-exhibition.
- Host museums may not charge a separate additional admission fee or "up-charge" in addition to their regular museum admission to allow visitors to visit the exhibition.
- Host museums may not sell exhibition for a fee (with the exception of transportation costs).
- Host museums may not charge a rental fee to travel the exhibition (with the exception of transportation costs).
- If the host museum gives away the exhibition to another institution, the host museum is responsible for ensuring that all restrictions listed above will transfer along with ownership of the mini-exhibition.

#### **Maintenance and Repair**

- Host museum is responsible for maintenance and repair of the exhibition while on display.
- A duplicate set of spare/loose parts will be provided; these consist of building pucks and rods for the "Build a Giant Carbon Nanotube" exhibit and blocks for the "Balance our Nano Future" exhibit.
- A technical support manual for the mini-exhibition will be provided

- Ongoing technical support, maintenance and additional spare/loose parts will not be provided for the mini-exhibition.

### **Shipping**

- The NISE Network will deliver the mini-exhibition to the owning host museum at no charge to the owning museum. The mini-exhibition will be shipped on pallets.

### **Set-up and Installation**

- Set-up and installation instructions will be provided.
- Host museum is responsible for actual installation.

### **Reporting Requirements:**

Host museums will be required to submit annual online reports (provided by the NISE Network) for up to four years upon receiving the exhibition to share their experiences of how they used or modified these products with the rest of the NISE Network. The report will include:

- a short narrative of how the exhibition was used
- the estimated number of visitor to the exhibition
- any modifications made to the exhibition

### **Publicity, Credit and Sponsorship**

Host museums will be responsible for all publicity, promotion and advertising relating to the display of the exhibition at their site. Whenever possible and where appropriate, credit should be given to the NISE Network and to the exhibition funder, the National Science Foundation (NSF); example text “This exhibition was created by the Nanoscale Informal Science Education Network (NISE). This project was supported by the National Science Foundation under Award Nos. 05322536 and 0940143.” Appropriate credit is included on the exhibition signage.



## EXHIBITION DISPOSAL

Though we don't look forward to it, the time will come for your *Nano* exhibition to be taken off your floor and disposed of, if you are unable to share it with another Network Partner. If you choose to dispose of the exhibition, note that certain efforts have been made to minimize the amount of material that ends up in a landfill when this exhibit is at the end of its run, and you can help ensure this with a small amount of effort when that time comes.

All of the graphic frames, table legs, and hardware are made of steel and can be recycled. The plywood panels and tabletops are designed to easily separate from the steel legs and frames using only a Phillips screwdriver or drill. A quick examination of each component is all that is needed to locate the screws that hold the component together.

The interior of the large upright graphics are honeycomb panels made of kraft paper, which is also recyclable. Remove the screws and plywood cap at the top of each graphic and simply slide the graphics and honeycomb spacer out of the frame.

Electrical components have been kept to a bare minimum, but even these few items should be disposed of properly rather than simply thrown in the trash.

Lastly, if your institution participates in a construction waste recycling program, the graphics can easily be removed and all of the tabletops, tables, plywood panels, and many of the plastic components recycled in a manner appropriate to your program.

Thank you in advance for making the extra effort.

## Acknowledgements



These materials were prepared with funding from the National Science Foundation under Award Nos. 0532536 and 0940143. Any opinions, findings, and conclusions or recommendations expressed in this report are those of the authors and do not necessarily reflect the views of the Foundation.



Copyright 2011 Science Museum of Minnesota, St. Paul, MN

Published under a Creative Commons Attribution-Noncommercial-Share Alike license:  
<http://creativecommons.org/licenses/by-nc-sa/3.0/us/>