

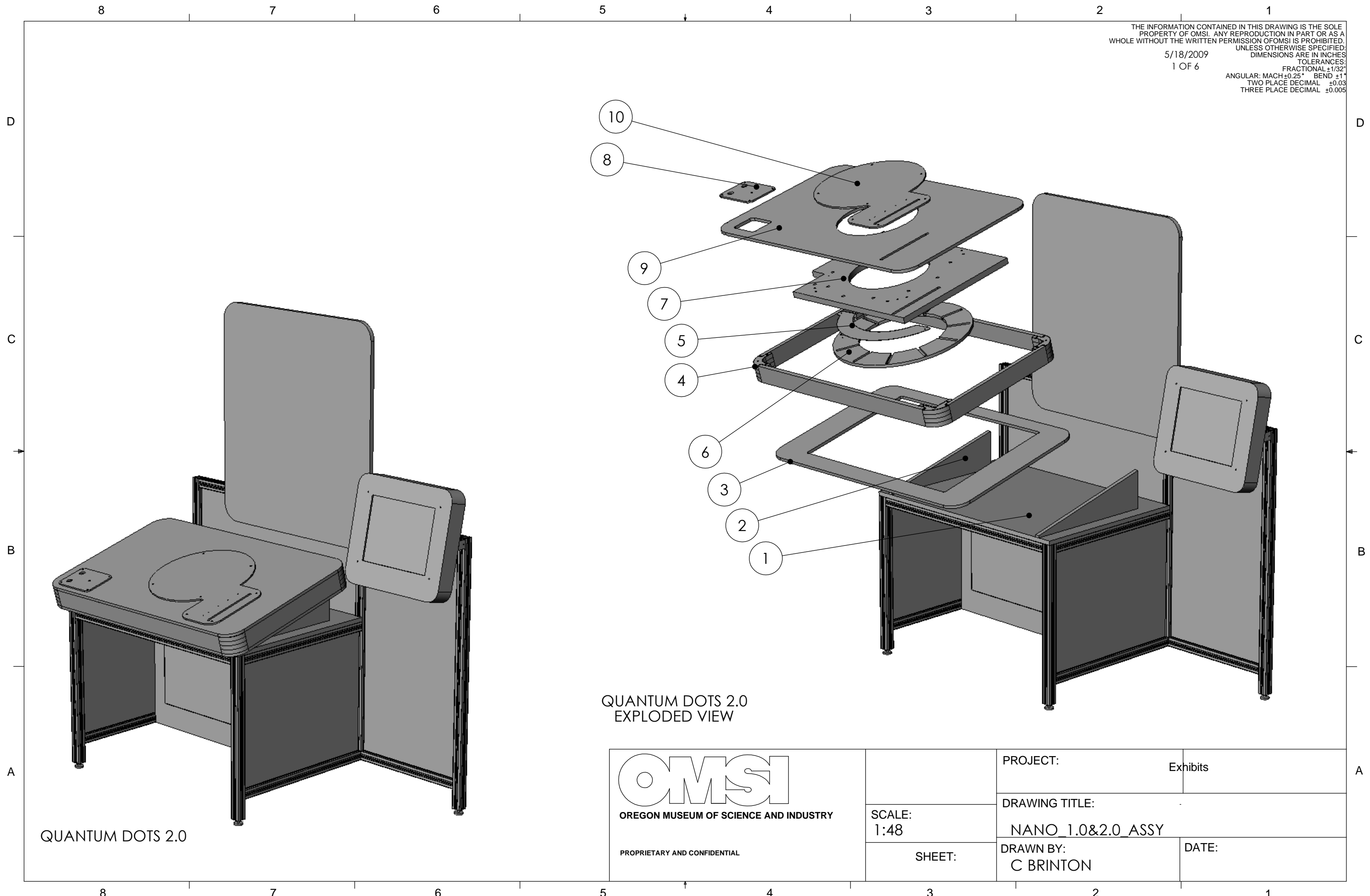

THE INFORMATION CONTAINED IN THIS DRAWING IS THE SOLE
 PROPERTY OF OMSI. ANY REPRODUCTION IN PART OR AS A
 WHOLE WITHOUT THE WRITTEN PERMISSION OF OMSI IS PROHIBITED.
 UNLESS OTHERWISE SPECIFIED:
 DIMENSIONS ARE IN INCHES
 TOLERANCES:
 FRACTIONAL ±1/32"
 DECIMAL ±0.005"
 ANGULAR: MACH ±0.25° BEND ±1°
 TWO PLACE DECIMAL ±0.03
 THREE PLACE DECIMAL ±0.005

5/18/2009
 1 OF 6



QUANTUM DOTS 2.0
 EXPLODED VIEW

QUANTUM DOTS 2.0

 OREGON MUSEUM OF SCIENCE AND INDUSTRY PROPRIETARY AND CONFIDENTIAL	SCALE: 1:48	PROJECT: Exhibits	
	SHEET:	DRAWING TITLE: NANO_1.0&2.0_ASSY	DATE:
		DRAWN BY: C BRINTON	

8 7 6 5 4 3 2 1

REVISIONS				
ZONE	REV.	DESCRIPTION	DATE	APPROVED

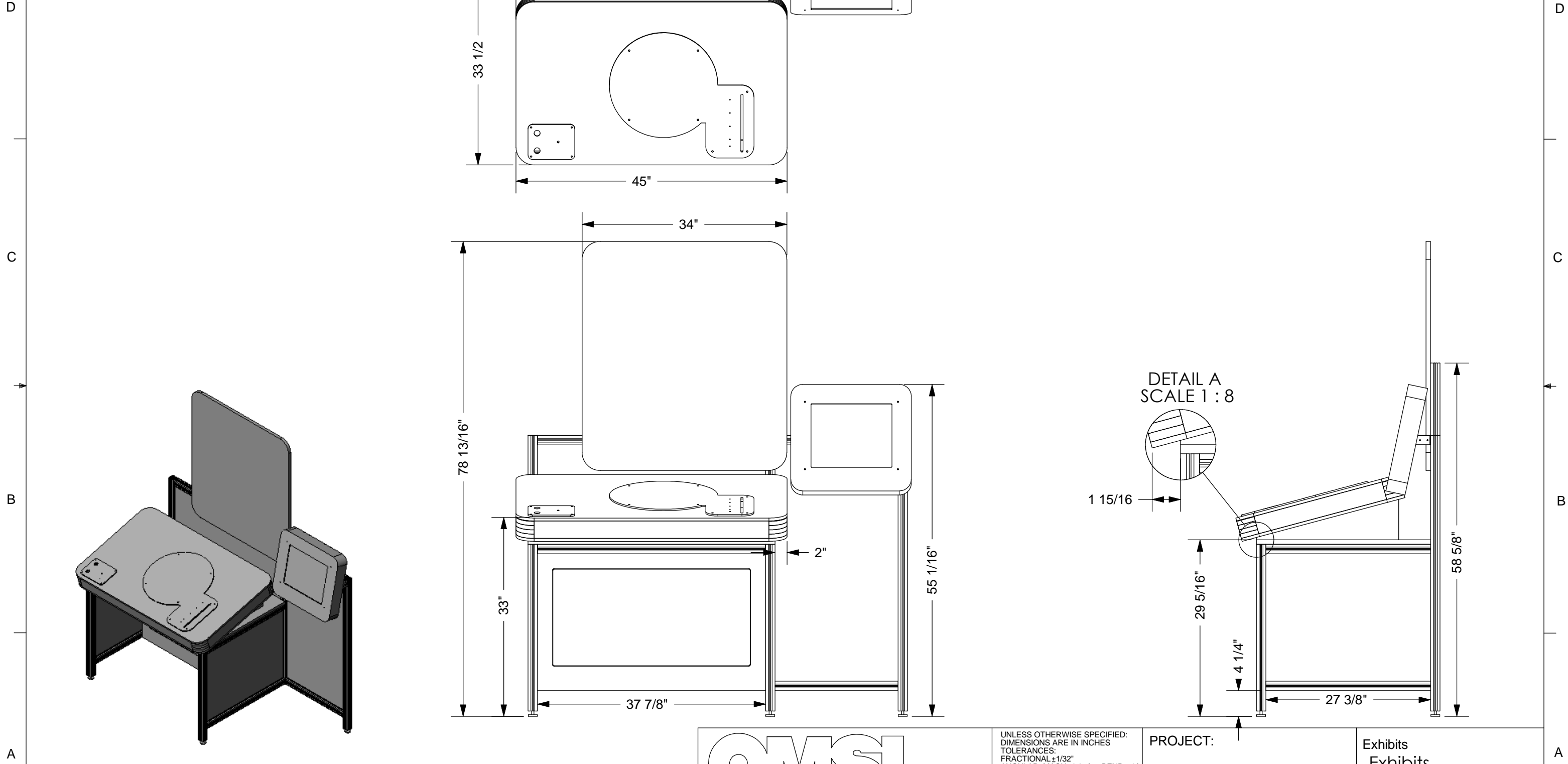

A

OMSI
OREGON MUSEUM OF SCIENCE AND INDUSTRY
 1945 SE WATER AVENUE
 PORTLAND, OR 97214-3354
 PH: 503.797.4000
 FAX: 503.797.4500
PROPRIETARY AND CONFIDENTIAL
 THE INFORMATION CONTAINED IN THIS DRAWING IS THE SOLE
 PROPERTY OF OMSI. ANY REPRODUCTION IN PART OR AS A
 WHOLE WITHOUT THE WRITTEN PERMISSION OF OMSI IS PROHIBITED.

UNLESS OTHERWISE SPECIFIED:
 DIMENSIONS ARE IN INCHES
 TOLERANCES:
 FRACTIONAL ±1/32"
 ANGULAR: MACH ±0.25° BEND ±1°
 TWO PLACE DECIMAL ±0.03
 THREE PLACE DECIMAL ±0.005

SCALE:
 1:24

SHEET:
 1 OF 1

PROJECT:
 Exhibits
 Exhibits

DRAWING TITLE:
 NANO_1.0&2.0_ASSY

DRAWN BY:
 C BRINTON

DATE:
 7/2/2009

8 7 6 5 4 3 2 1

THE INFORMATION CONTAINED IN THIS DRAWING IS THE SOLE PROPERTY OF OMSI. ANY REPRODUCTION IN PART OR AS A WHOLE WITHOUT THE WRITTEN PERMISSION OF OMSI IS PROHIBITED. UNLESS OTHERWISE SPECIFIED: DIMENSIONS ARE IN INCHES. TOLERANCES: FRACTIONAL ±1/32" ANGULAR: MACH ±0.25° BEND ±1° TWO PLACE DECIMAL ±0.03 THREE PLACE DECIMAL ±0.005

5/18/2009
3 OF 6

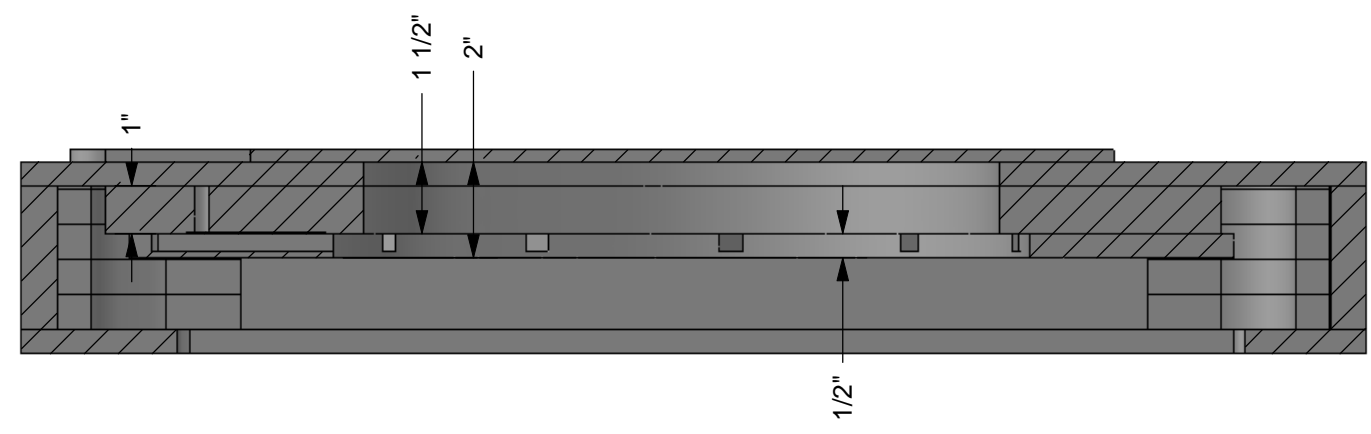
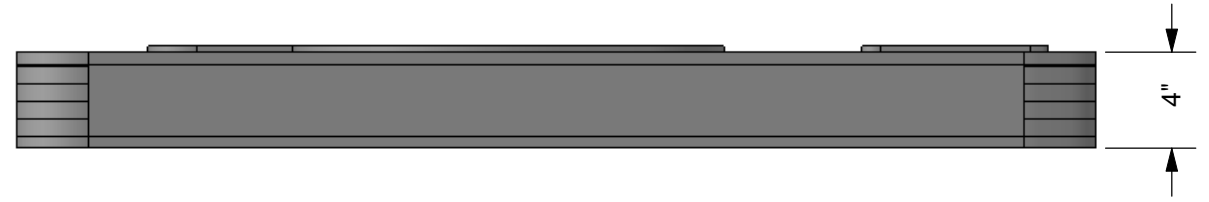

SECTION L-L
SCALE 1 : 4

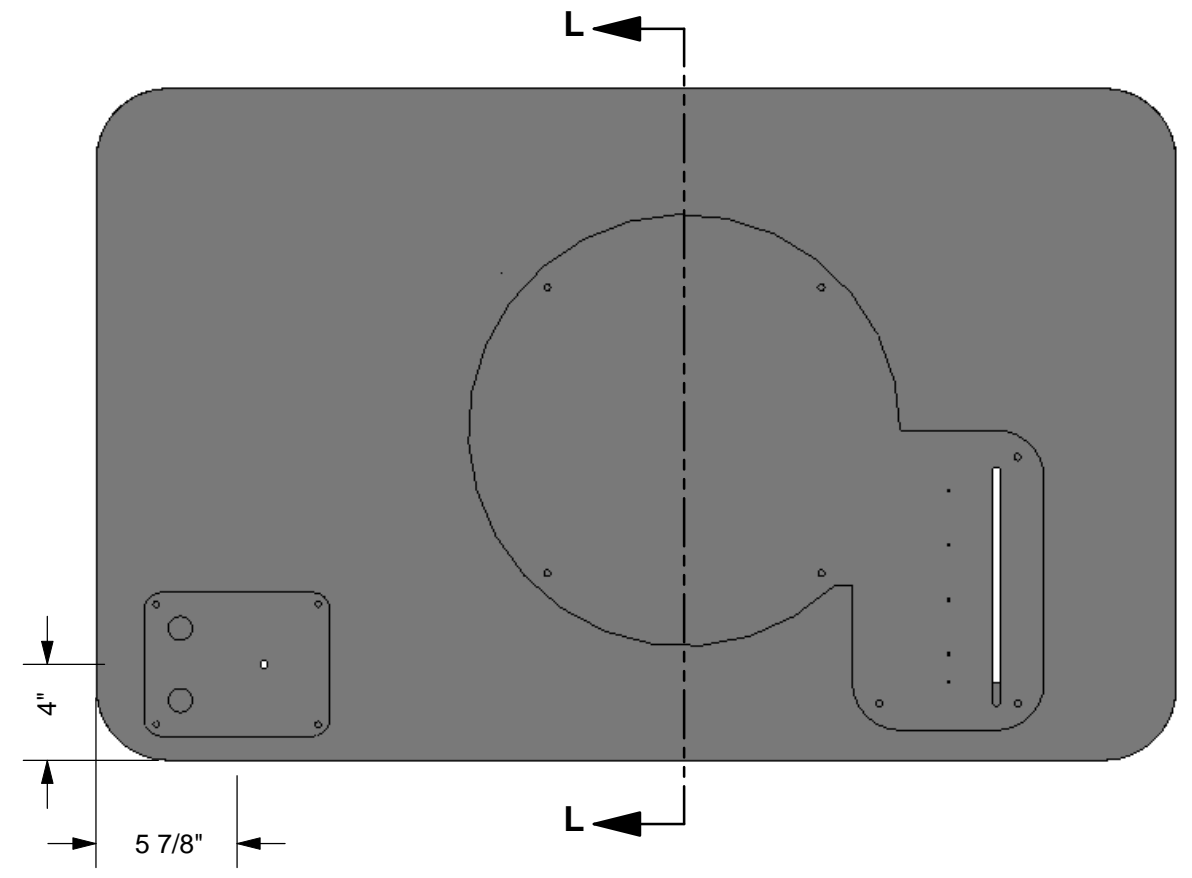

 OREGON MUSEUM OF SCIENCE AND INDUSTRY PROPRIETARY AND CONFIDENTIAL	PROJECT:	Exhibits
	SCALE:	1:48
	SHEET:	
	DRAWING TITLE:	QUANTUM DOTS_ASSEMBLY
	DRAWN BY:	C BRINTON
	DATE:	

THE INFORMATION CONTAINED IN THIS DRAWING IS THE SOLE
 PROPERTY OF OMSI. ANY REPRODUCTION IN PART OR AS A
 WHOLE WITHOUT THE WRITTEN PERMISSION OF OMSI IS PROHIBITED.
 5/18/2009
 4 OF 6
 UNLESS OTHERWISE SPECIFIED:
 DIMENSIONS ARE IN INCHES
 TOLERANCES:
 FRACTIONAL $\pm 1/32"$
 ANGULAR: MACH $\pm 0.25^\circ$ BEND $\pm 1^\circ$
 TWO PLACE DECIMAL ± 0.03
 THREE PLACE DECIMAL ± 0.005

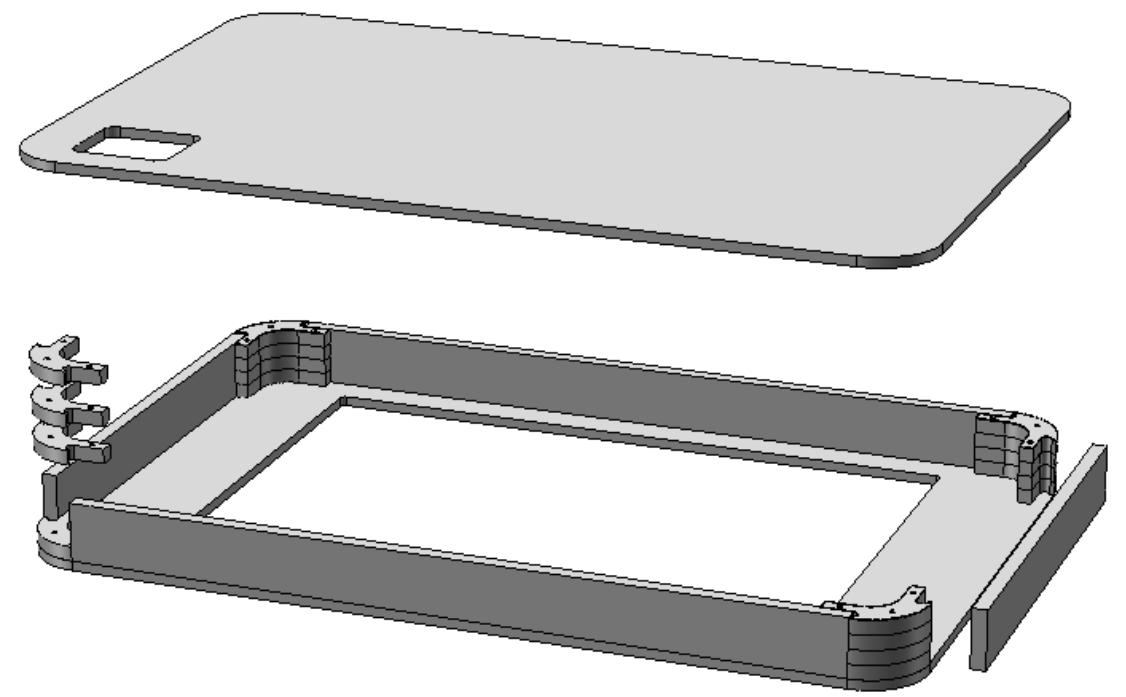
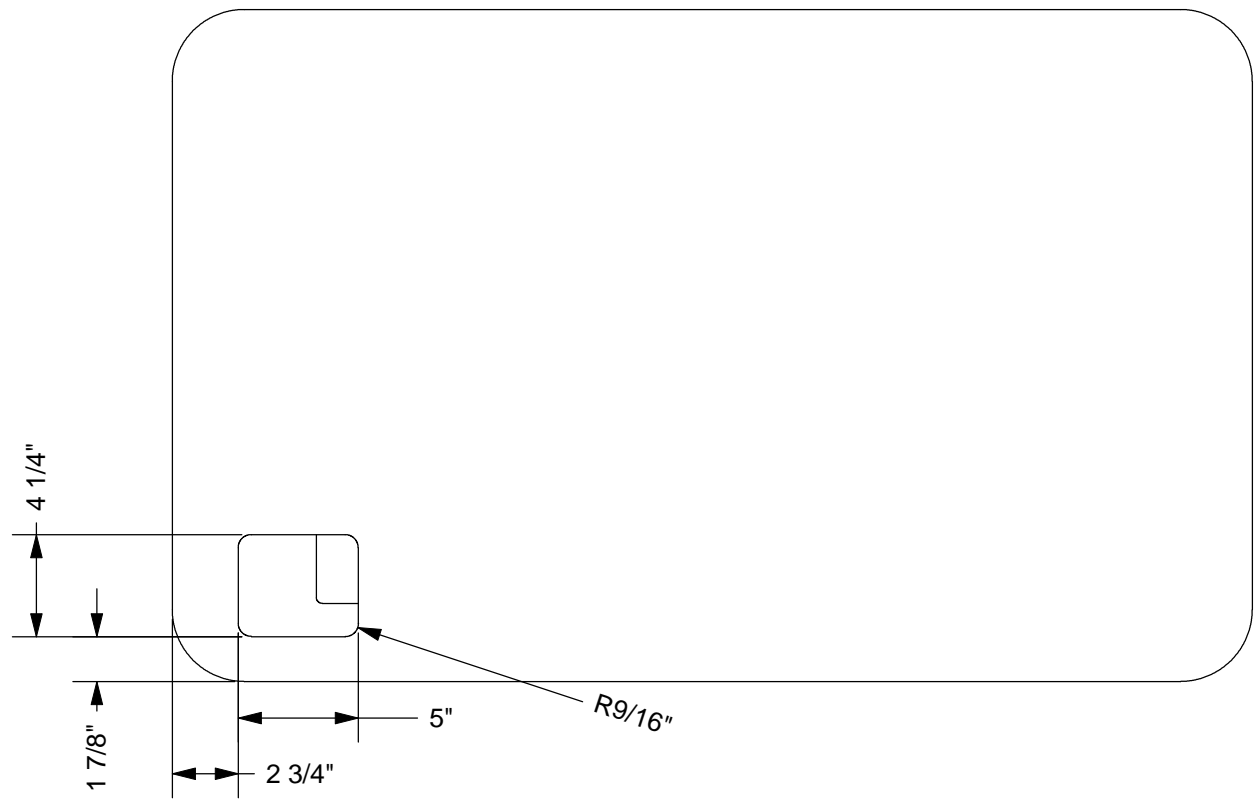

EXPLODED VIEW

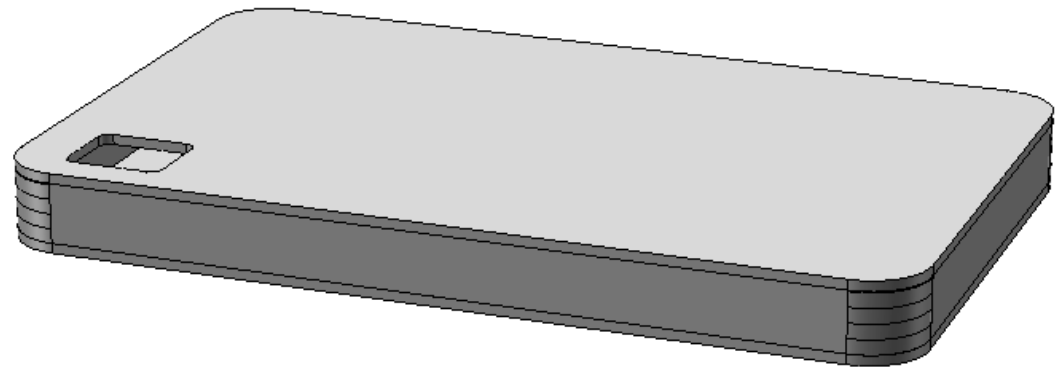

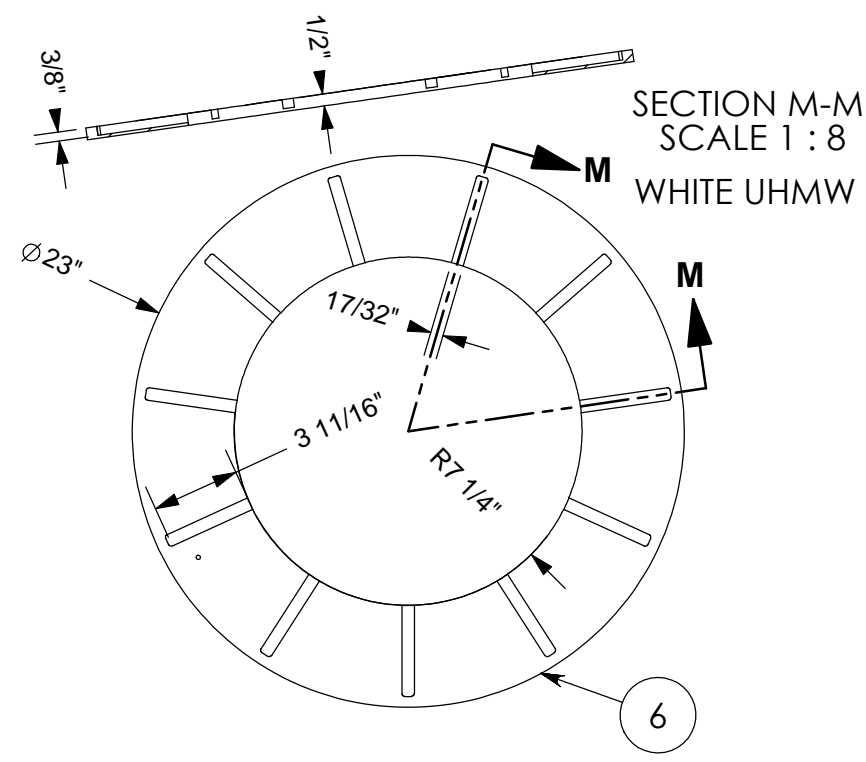
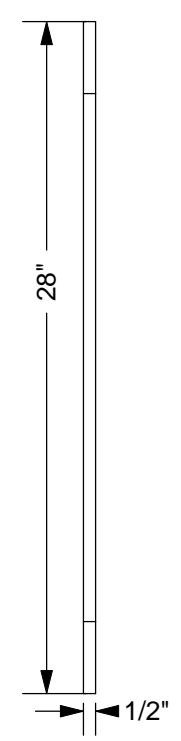
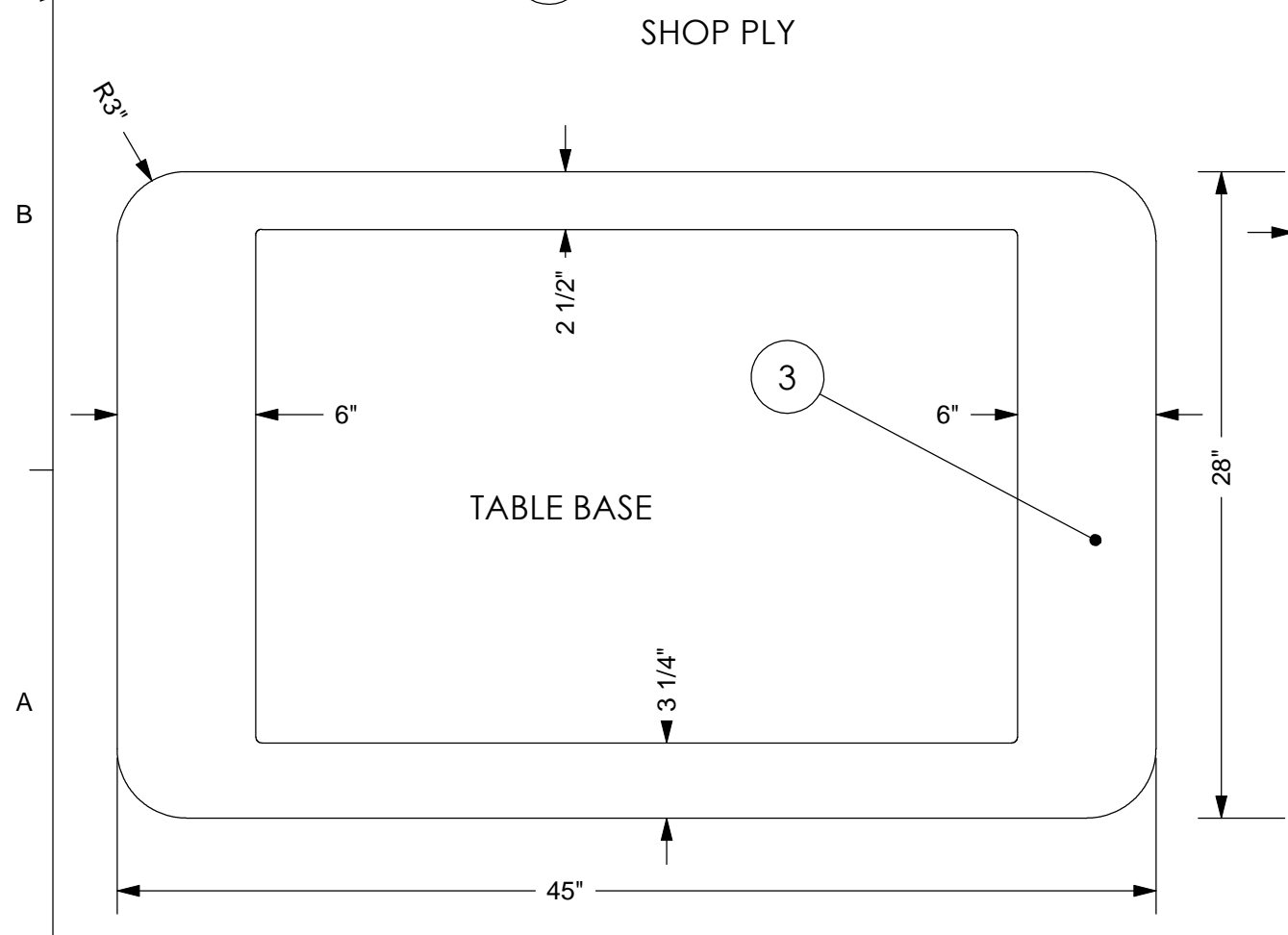
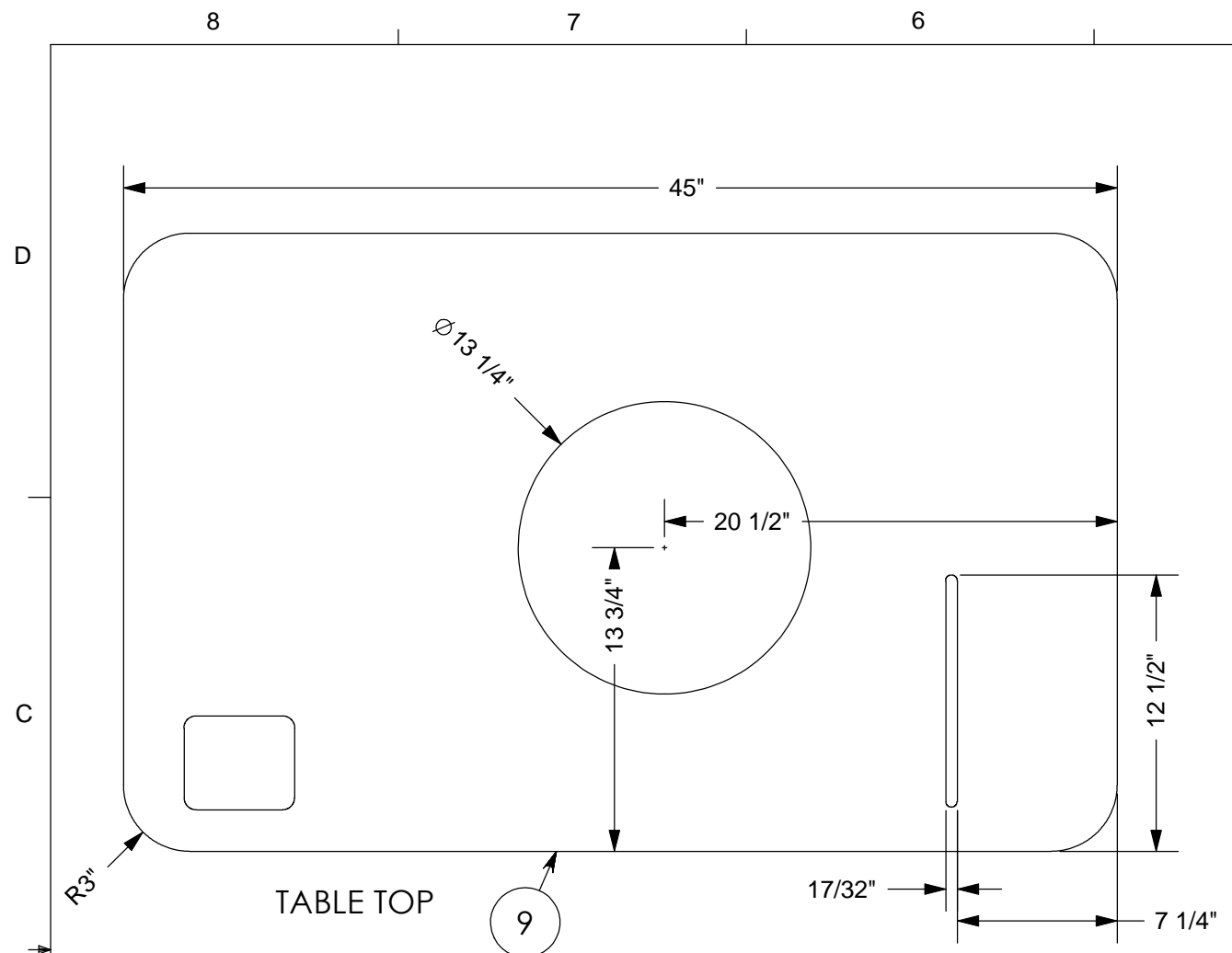

TABLE ASSEMBLY COMMON TO ALL COMPONENTS
 (BLANK TABLE TOP SHOWN)

 OREGON MUSEUM OF SCIENCE AND INDUSTRY PROPRIETARY AND CONFIDENTIAL	PROJECT:	Exhibits
	SCALE:	1:48
	SHEET:	
	DRAWING TITLE:	DEFAULT TABLE ASSEMBLY
	DRAWN BY:	C BRINTON
	DATE:	

THE INFORMATION CONTAINED IN THIS DRAWING IS THE SOLE PROPERTY OF OMSI. ANY REPRODUCTION IN PART OR AS A WHOLE WITHOUT THE WRITTEN PERMISSION OF OMSI IS PROHIBITED. UNLESS OTHERWISE SPECIFIED, DIMENSIONS ARE IN INCHES. TOLERANCES: FRACTIONAL $\pm 1/32"$ ANGULAR: MACH $\pm 0.25^\circ$ BEND $\pm 1^\circ$ TWO PLACE DECIMAL ± 0.03 THREE PLACE DECIMAL ± 0.005

5/18/2009
5 OF 6



REFER TO CAD DATA FOR DIMENSIONS

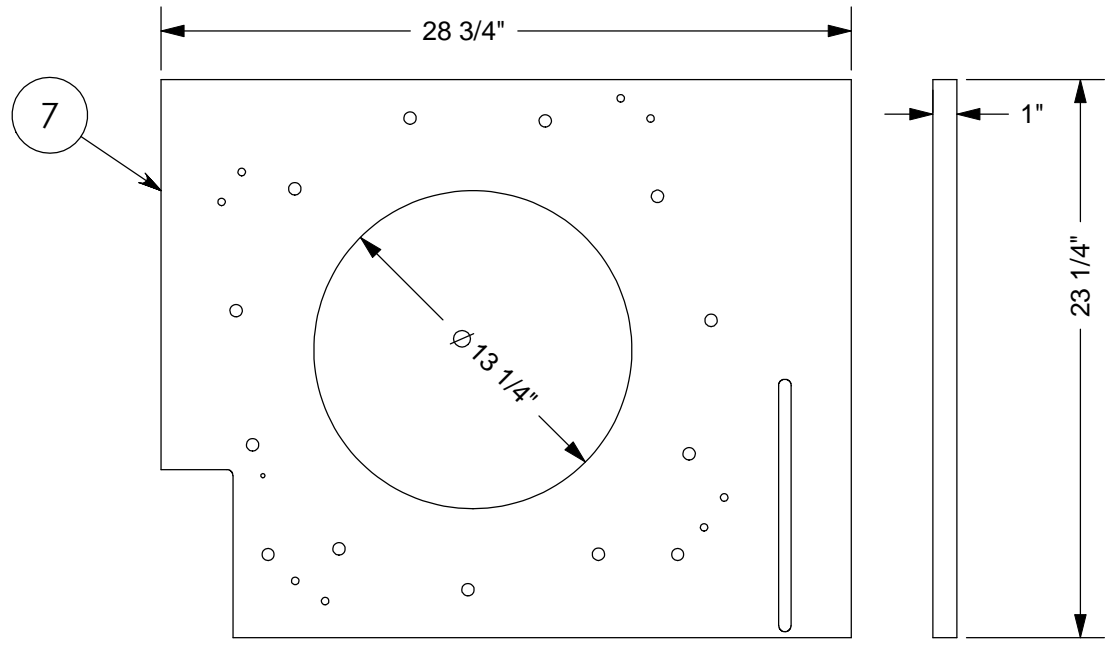
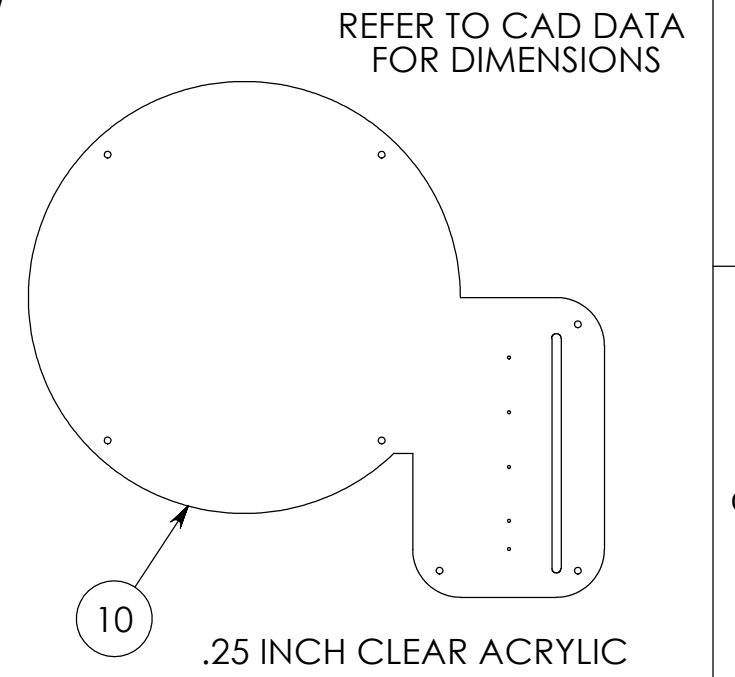

 OREGON MUSEUM OF SCIENCE AND INDUSTRY PROPRIETARY AND CONFIDENTIAL	SCALE: 1:48	PROJECT: Exhibits
	SHEET:	DRAWING TITLE: QD_TABLE TOP LEVER CUT
		DRAWN BY: C BRINTON

THE INFORMATION CONTAINED IN THIS DRAWING IS THE SOLE PROPERTY OF OMSI. ANY REPRODUCTION IN PART OR AS A WHOLE WITHOUT THE WRITTEN PERMISSION OF OMSI IS PROHIBITED. UNLESS OTHERWISE SPECIFIED: DIMENSIONS ARE IN INCHES. TOLERANCES: FRACTIONAL: ±1/32" ANGULAR: MACH ±0.25° BEND ±1° TWO PLACE DECIMAL ±0.03 THREE PLACE DECIMAL ±0.005

5/18/2009
6 OF 6

.25 INCH CLEAR ACRYLIC

D
C
B
A

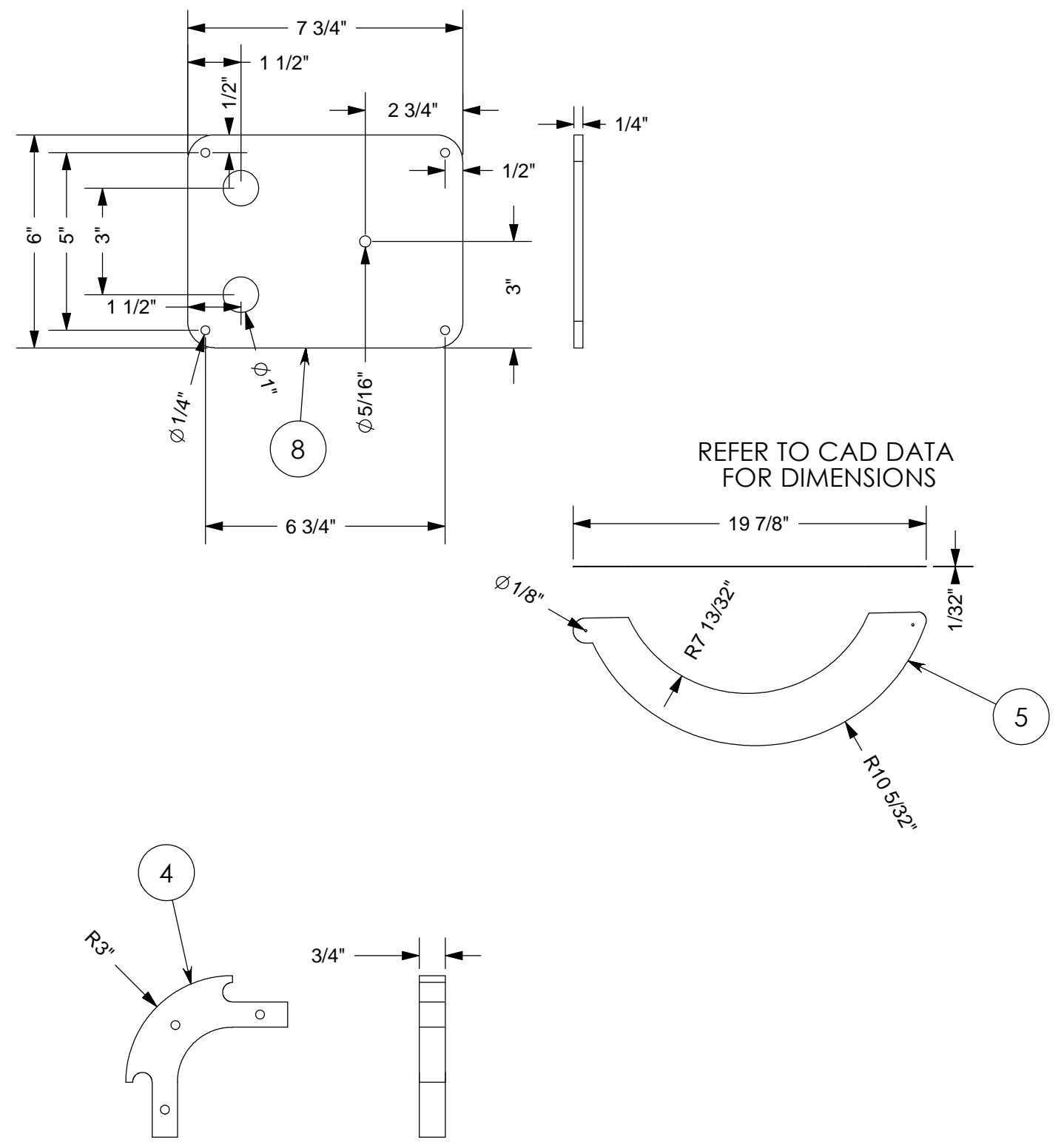

REFER TO CAD DATA FOR DIMENSIONS

REFER TO CAD DATA FOR DIMENSIONS

FRAME TABLE TOP

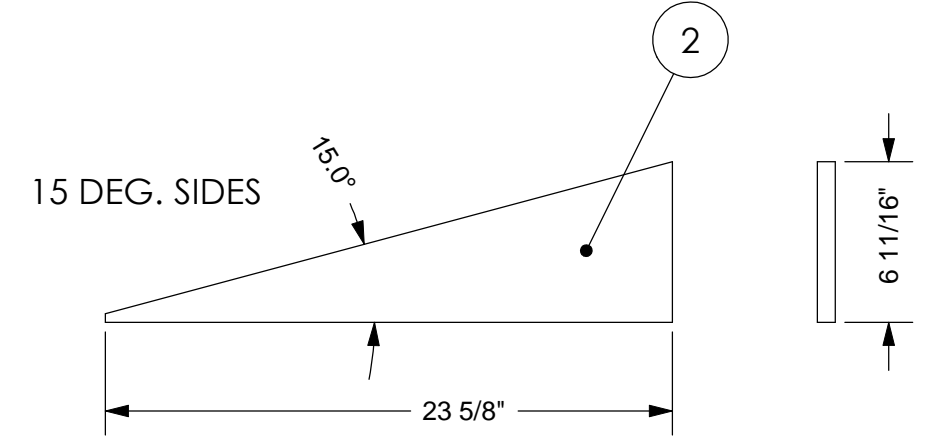
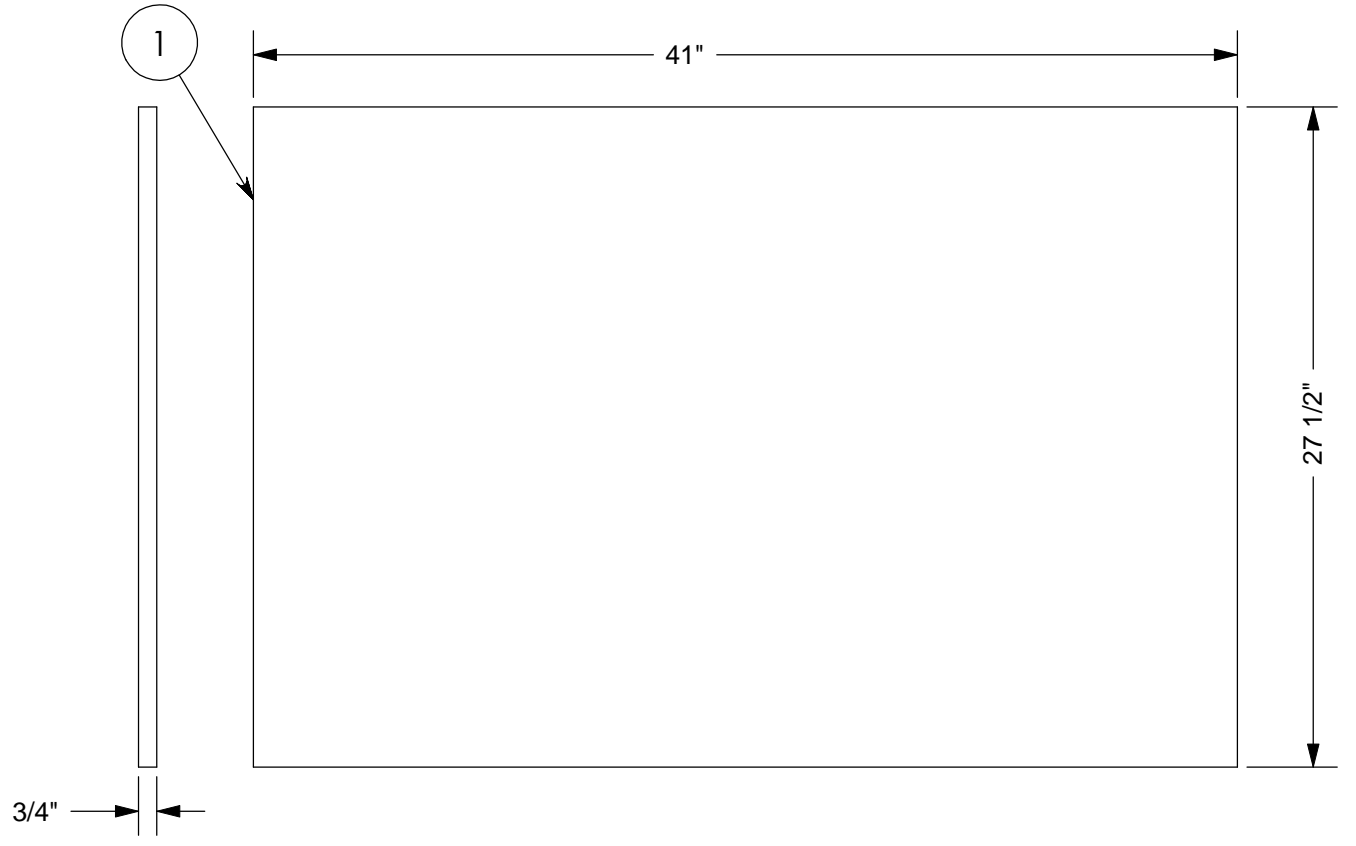

 OREGON MUSEUM OF SCIENCE AND INDUSTRY PROPRIETARY AND CONFIDENTIAL	PROJECT:	Exhibits
	SCALE:	1:48
	DRAWING TITLE:	Body183
SHEET:	DRAWN BY:	C BRINTON
	DATE:	

8 7 6 5 4 3 2 1